

3M Purification

Life Sciences Process Technologies Markets

LENNTECH

info@lenntech.com Tel. +31-152-610-900

www.lenntech.com Fax. +31-152-616-289



LifeASSURE™ PSA

Series Capsules & Cartridges

Robust sterilising-grade Nylon 6,6 membrane Filter

- ☑ New name for CUNO SterASSURE capsules and cartridges
- ☑ Robust sterile filtration performance and high throughput capacity
- ☑ Double layer multi-zone microporous membrane construction with Advanced Pleat Technology design
- ☑ Available in 0.1 and 0.2 μm pore sizes in cartridge and capsule formats

3M

Figure 1: SEM of FlexN Membrane

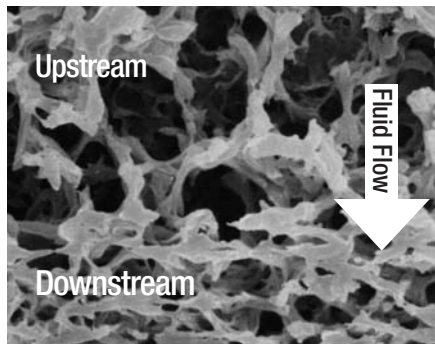

LifeASSURE PSA filter cartridges and capsules

Encompassing two leading-edge processes, multi-zone microporous membrane manufacture and Advanced Pleating Technology (APT) design, LifeASSURE™ PSA filters offer robust 0.1 and 0.2 µm absolute-rated filtration and exceptionally long service life. Designed with two layers of pleated Nylon 6,6 membrane in an all-polypropylene cartridge construction, LifeASSURE PSA filters, formerly known as CUNO SterASSURE, are ideally suited for a wide range of sterilising applications in the pharmaceutical, biological and bioprocess industries.

- ▶ LifeASSURE PSA filters, coupled with a LifeASSURE™ PLA prefilter, outperform competitive prefilter-final filter systems by up to 5 times.
- ▶ LifeASSURE PSA filters, using double layer multi-zone microporous membrane, provide higher throughput than competitive 0.1 and 0.2 micron-rated filters.
- ▶ LifeASSURE PSA sterilising-grade final filters and 3M Purification LifeASSURE PLA prefilters are constructed from like materials to ease validation and reduce product compatibility concerns.

Multi-zone microporous membrane technology

LifeASSURE PSA filters incorporate an advanced 3M Purification multi-zone microporous membrane technology. It allows unmatched flexibility in creating a multi-zone membrane that offers maximum contaminant holding capacity while maintaining high retention efficiency. The SEM photograph (figure 1) shows a single layer of LifeASSURE PSA multi-zone microporous membrane consisting of an open zone and a tighter, qualifying zone. This multi-zone membrane construction capability results in a membrane that provides exceptionally high throughput. In making LifeASSURE PSA filter cartridges, two layers of multi-zone microporous membrane are combined to produce a robust sterilising-grade filter.

LifeASSURE PSA sterilising-grade filters are available in cartridge and capsule configuration with absolute ratings of 0.1 and 0.2 µm.

LifeASSURE PSA filters are designed for use with LifeASSURE PLA prefilter cartridges for optimal system performance.

Features and Benefits

Robust double layer membrane filter construction

- Exceptional robustness and increased security

APT (Advanced Pleat Technology) construction

- Allows maximum fluid and contaminant access to filter surface area for highest throughput

100% Integrity tested prior to release

- Ensures consistent performance to specification

21 CFR materials of construction

Passes USP Biological Safety Test for Plastics - Class VI

Validation Guide and Drug Master File (DMF)

- Eases validation and regulatory submissions

Validated 0.1 and 0.2 µm absolute-rated membrane

- Reliable sterilising filtration and retention of mycoplasma

Applications

LifeASSURE™ PSA filters are optimised for applications requiring critical sterilisation where 0.1 or 0.2 µm absolute-rated filtration is required. The multi-zone microporous double layer membrane construction allows robust sterilising performance and exceptionally high contaminant capacity. LifeASSURE PSA filters are designed for a broad range of aqueous and solvent based pharmaceutical, biological and bioprocess applications, including:

- 0.1 and 0.2 µm final sterilising filtration
- Media and fermenter feed streams
- Parenterals (SVP, LVP)
- Solvent filtration
- Reagents & buffers
- Orals & topicals
- Biologicals
- Serum & blood fractions
- High-Purity DI water and WFI systems
- Bulk pharmaceutical chemicals

Meeting scale-up and scale-down requirements

A full range of LifeASSURE PSA sterilising-grade filters are available to meet your scale-up and scale-down process needs. LifeASSURE PSA membrane is configured in disposable capsules, mini-cartridges and full-size cartridges. Smaller LifeASSURE PSA membrane areas can be obtained by using LifeASSURE PSA filter discs.

LifeASSURE PSA filter configurations		
Disposable capsule filters	Mini-cartridges	Full-size cartridges
<ul style="list-style-type: none"> • 2.5", 5", 10", 20", 30" sizes • 0.14 to 2.82 m² • Completely contained, no housing required • Sanitary flange and hose barb connections (see ordering guide) • Autoclavable 	<ul style="list-style-type: none"> • 2.5" and 5" sizes • 0.14 to 0.33 m² • 2.5" and 5" housings available for lowest hold up volume design • Retrofit for competitors' filter housings • Steam in place (SIP) or autoclaveable 	<ul style="list-style-type: none"> • 5" through 40" lengths • > 0.86 m²/10" • Double O-ring seal mechanism • Fits 3M Purification and competitor filter housings • Steam in place (SIP) or autoclaveable

LifeASSURE PSA flow rate performance

Shown in figure 2 are liquid flow curves for LifeASSURE PSA cartridge and capsule filter assemblies by membrane rating. For details of system sizing, please consult your local 3M Purification distributor.

Advanced Pleat Technology construction

LifeASSURE PSA filters also feature the Advanced Pleat Technology (APT) design for extended service life. This design technology helps maximise the useful surface area of the filter while maintaining open flow paths between media pleats (figure 3). By employing the APT design, the LifeASSURE PSA filter provides lower pressure drops, longer service life and lower overall filtration costs.

Figure 2: LifeASSURE™ PSA cartridge and capsule flow rates (Clean water at 25 °C)

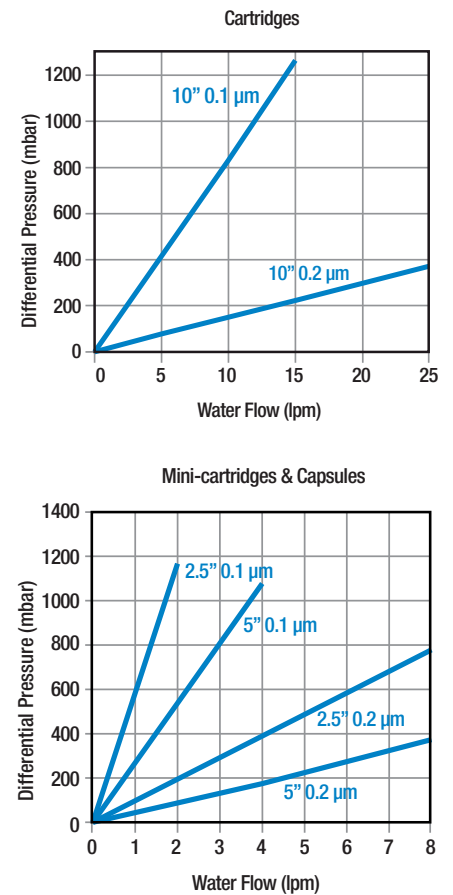

Figure 3: Advanced Pleat Technology

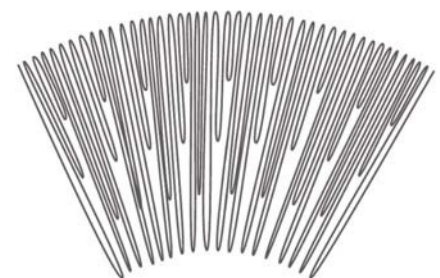

Chart 1: 0.2 µm filter throughput comparison

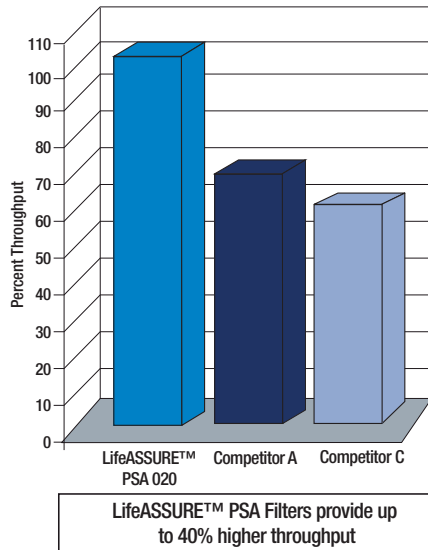
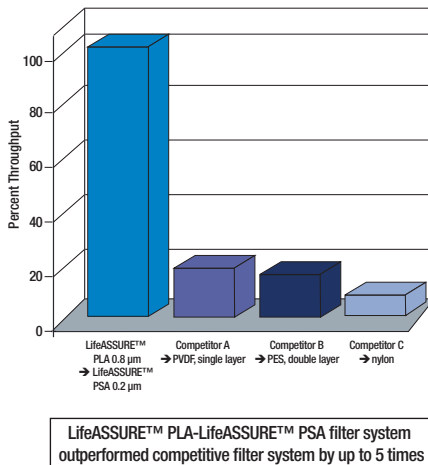

Chart 2: Prefilter - final filter 0.2 µm combined throughput comparison



Superior microorganism retention

LifeASSURE™ PSA 0.1 and 0.2 µm rated filters are qualified for absolute retention (table 2) of *B. diminuta* (ATCC 19146) following American Society of Testing and Materials (ASTM) methodology at a minimum challenge level of 10^7 CFU/cm² of filter area. The results of bacteria challenge testing are correlated to non-destructive integrity testing. LifeASSURE PSA 0.1 µm rated filters are further qualified for absolute retention of mycoplasma (*Acholeplasma laidlawii*, ATCC 23206). For complete details ask for the 3M Purification LifeASSURE PSA Validation Guide.

Filter	Challenge organism	Challenge level	Result
LifeASSURE™ PSA 0.1 µm	<i>B. diminuta</i>	$>10^7$ /cm ²	Sterile effluent
LifeASSURE™ PSA 0.1 µm	<i>A. laidlawii</i>	$>10^7$ /cm ²	Sterile effluent
LifeASSURE™ PSA 0.2 µm	<i>B. diminuta</i>	$>10^7$ /cm ²	Sterile effluent

Optimised for service life and sterilising filtration performance

As the data in chart 1 demonstrates, LifeASSURE PSA filters are designed to provide both enhanced service life and performance. Using a model contaminant solution, the throughput of LifeASSURE PSA 0.2 µm rated filters was compared to competitive 0.2 µm rated filters. The results show the significantly higher throughput obtained with 3M Purification LifeASSURE PSA filters.

Optimised for use with LifeASSURE PLA prefilter cartridges and capsules

LifeASSURE PSA sterilising-grade filters are designed for use with LifeASSURE™ PLA prefilters. Because both filters feature a multi-zone microporous Nylon 6,6 filter membrane, the sources of extractables and potential product interactions are reduced compared to systems employing prefilters and final filters with different materials of construction. In addition, the multi-zone microporous membrane technology provides superior system throughput. In order to compare throughput performance of the LifeASSURE PLA - LifeASSURE PSA filter system to competitive prefilter-final filter systems, studies were performed using a model contaminant. The results, as depicted in chart 2, show that the LifeASSURE PLA - LifeASSURE PSA filter system outperformed competitive filter systems by 4 to 5 times.

For optimum throughput, use LifeASSURE PLA 0.8 µm rated filters upstream of LifeASSURE PSA 0.2 µm rated filters and LifeASSURE PLA 0.45 µm rated filters upstream of LifeASSURE PSA 0.1 µm rated filters. We encourage you to experience the 3M Purification performance advantage by arranging an on-site filter test. For more information about testing and LifeASSURE PLA filters contact your local 3M Purification office or distributor.

Robust filtration performance

LifeASSURE PSA filters are constructed using two layers of multi-zone microporous membrane. The two membrane layers are laminated such that the qualifying zones are sandwiched in the centre of the structure. This construction provides protection to the qualifying zones, enhancing filter robustness.

In order to measure design robustness, sample filters were subjected to multiple *in situ* steam sterilisation cycles or exposure to 25 °C, 1M sodium hydroxide. Table 2 shows the results of these studies. Thermal cycling represents a severe test of structural integrity due to the elevated temperature exposure and expansion and contraction of filter components. Caustic compatibility is a desirable feature for chromatography column prefiltration where caustic fluids used for column sanitisation and regeneration can be passed directly through LifeASSURE PSA filters.

Table 2: Thermal and chemical compatibility

Test	Exposure conditions	Post exposure integrity test result
<i>In situ</i> steam sterilisation	135 °C, minimum 15 cycles of 30 minutes	Pass
1 M sodium hydroxide exposure	5 hours cumulative exposure at 25 °C	Pass

Performance engineered cartridge design

LifeASSURE™ PSA filter cartridges are available in 5”, 10”, 20”, 30” and 40” lengths. All-polypropylene structural components (end caps, adapters, media support, inner core and outer cage) are used in the fabrication ensuring exceptional thermal and mechanical stability, broad chemical compatibility and low extractable levels. LifeASSURE PSA cartridge configurations are available to match dimension and sealing requirements of most currently available cartridge housings.

Mini-cartridges

For critical small volume applications, LifeASSURE PSA filters are available in 2.5” and 5” mini-cartridges. Installed in a 3M Purification 2.5” or 5” mini-cartridge housing, or in existing competitors’ housings, LifeASSURE PSA mini-cartridges offer low hold-up volume and economical small volume filtration.

Disposable filter capsules

For critical applications where convenience and ease of use are desired, LifeASSURE PSA filters are available in 2.5, 5, 10, 20 and 30” disposable capsules. LifeASSURE PSA capsules are supplied with sanitary vent and drain ports, as well as a choice of 1 ½” sanitary flange connections or ½” (13 mm) hose barb inlet/outlet connections. Silicone vent/drain O-rings are standard, for other O-ring materials, consult your local 3M Purification office or distributor.

LifeASSURE PSA specifications

		Cartridges 5” to 40”	Mini-cartridges		Capsules				
			2.5”	5”	2.5”	5”	10”	20”	30”
Material of construction									
Cage, Core, end caps, capsule shell and media support layers		polypropylene							
Membrane		double layer multi-zone microporous Nylon 6,6 membrane							
Adapter support ring		316 stainless steel	N/A						
Filtration surface area (m ²)	0.1 µm	0.94*	0.16	0.33	0.16	0.33	0.94	1.89	2.83
	0.2 µm	0.86*	0.14	0.28	0.14	0.28	0.86	1.72	2.57
Operating parameters									
Maximum operation temperature		80 °C				40 °C			
Maximum differential pressure		Forward : 5.5 bar at 25 °C 1.7 bar at 80 °C				5.2 bar at 40 °C **			
		Reverse : 3.4 bar at 25 °C							
Steam sterilisation		30 minutes at 135 °C				Do not <i>in situ</i> steam			
Autoclave sterilisation						30 minutes at 126 °C			
Diffusion flow test (water wet) in ml/min. ***	0.1 µm (4830 mbar)	≤ 18.0 *	≤ 3.0	≤ 6.3	≤ 3.0	≤ 6.3	≤ 18.0	≤ 36.0	≤ 54.0
	0.2 µm (2415 mbar)	≤ 13.1 *	≤ 2.1	≤ 4.3	≤ 2.1	≤ 4.3	≤ 13.1	≤ 26.2	≤ 39.3
Bubble point***		Mini BP for 0.1 µm is 5102 mbar				Mini BP for 0.2 µm is 2620 mbar			

* Per 10” element

** Also correspondent to maximum operating pressure

*** at 1 atmosphere pressure and 25 °C

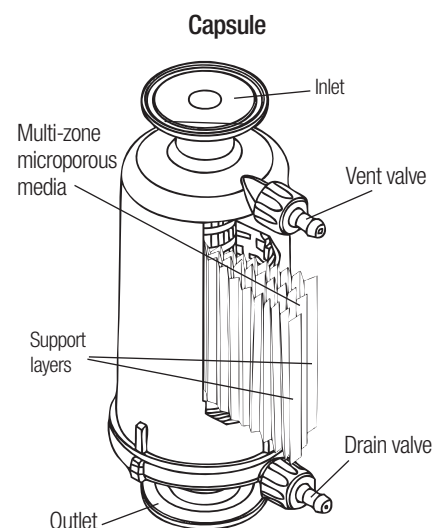
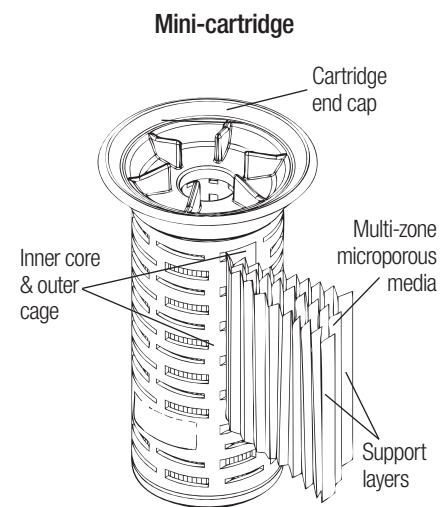
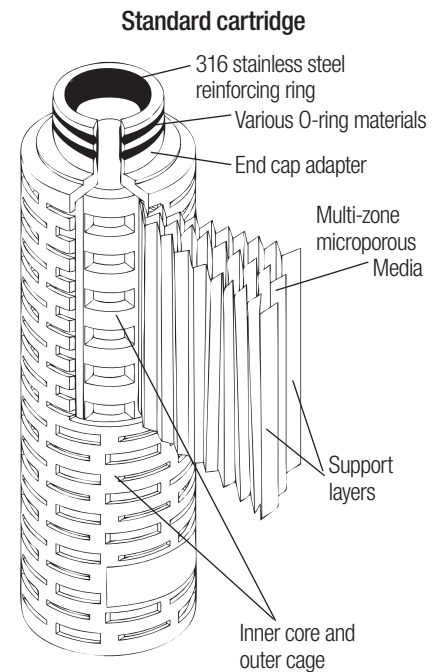



Validation support services

3M Purification offers specialised support to the pharmaceutical and biotechnology industry through our Scientific Applications Support Services (SASS) group. SASS routinely provides end-users with:

- Validation and regulatory support
- Extractable and compatibility analysis
- Filter system optimisation studies

For more information regarding 3M Purification’s validation support services, please contact 3M Purification Technical Services.

Quality and reliability

LifeASSURE™ PSA filters are manufactured to an ISO registered quality system and are 100% diffusion flow tested prior to shipment. All materials of construction are 21 CFR listed and cartridge and capsule filter components have been tested in accordance with United States Pharmacopoeia (USP) Biological Safety test - Class VI. All LifeASSURE PSA cartridge and capsule filters are shipped with a Certificate of Quality affirming compliance with rigid manufacturing quality specifications. Supporting Drug Master File (DMF) documentation is on file with the United States Food and Drug Administration (FDA). A complete LifeASSURE PSA Validation Guide is available upon request.



Filter housings

A specialised range of filter housings is available to meet the needs of the pharmaceutical, biological and bioprocess industries. They provide easy access for filter change-out and the greatest assurance that LifeASSURE PSA filter cartridges are sealed securely, thus eliminating the possibility of fluid bypass. All housings are constructed using 316L stainless steel to maximise corrosion resistance. Internal surfaces of the housings are polished to 0,8 Ra max. to limit microbial adhesion and provide easy cleaning.

Housing IW Specifications	01 IW / 03 IW / 05 IW / 08 IW	12 IW	18 IW / 24 IW
Design code	AD Merkblätter 95		
Housing material (in contact)	316L (1.4404) stainless steel		
Surface finish	mechanical polish < 0.8 micron Ra		
Closure	clamped	bolted	bolted
Number of cartridges	1 - 3 - 5 - 8	12	18 -24
Standard gasket material	silicone (others on request)		
Cartridge height	1, 2, 3 and 4 high		3 and 4 high
Connection sizes	<ul style="list-style-type: none"> • threaded Male DIN 11851 • triclover 	<ul style="list-style-type: none"> • DIN 2633 flanges • MACON 	
Vent connections	½" TC		
Max. operating pressure	10 bar g	9 bar g	8 bar g
Max. operating temperature	150 °C		
PED 97/23/CE	Category I		Category I (18 IW) Category II (24 IW)
ATEX 94/9/CE	II-2-G/D-T5		

Table 1 is intended as a guide. Grade selection and performance should be confirmed with small-scale pilot trial.

LifeASSURE™ PSA cartridges - Ordering guide

Grade designation	Configuration	Height (inches)	End modification	O-ring material
PSA 010 - 0.1 µm PSA 020 - 0.2 µm	F	01 - 10 02 - 20 03 - 30 04 - 40 50 - 5	B - 226 O-ring & spear C - 222 O-ring & spear F - 222 O-ring & flat cap J - 226 O-ring & flat cap	A - silicone (MVQ)* B - fluorocarbon (FPM)* C - EPR (EPDM)* D - nitrile (NBR)* K - PTFE-encapsulated fluorocarbon

*ISO Designation

LifeASSURE™ PSA mini-cartridges - Ordering guide

Grade designation	Configuration	Height (inches)	End modification	Package quantity
PSA 010 - 0.1 µm PSA 020 - 0.2 µm	M	01 - 2,5 02 - 5	AN	06 - 6 Pack

LifeASSURE™ PSA capsules - Ordering guide

Grade designation	Configuration	Height (inches)	End modification	Vent O-ring option	Package quantity
PSA 010 - 0.1 µm PSA 020 - 0.2 µm	C - small capsules	01 - 2,5 02 - 5	A - sanitary fitting B - ½" hose barb	A - silicone B - fluorocarbon C - EPR	01 - 1 Pack
	J - large capsules	01 - 10 02 - 20 03 - 30	A - sanitary fitting		

NOTE: LifeASSURE PSA is new name for CUNO SterASSURE.



Important Notice

The information described in this literature is accurate to the best of our knowledge. A variety of factors, however, can affect the performance of the Product(s) in a particular application, some of which are uniquely within your knowledge and control. INFORMATION IS SUPPLIED UPON THE CONDITION THAT THE PERSONS RECEIVING THE SAME WILL MAKE THEIR OWN DETERMINATION AS TO ITS SUITABILITY FOR THEIR USE. IN NO EVENT WILL 3M PURIFICATION BE RESPONSIBLE FOR DAMAGES OF ANY NATURE WHATSOEVER RESULTING FROM THE USE OF OR RELIANCE UPON INFORMATION.

It is your responsibility to determine if additional testing or information is required and if this product is fit for a particular purpose and suitable in your specific application.

3M PURIFICATION MAKES NO REPRESENTATIONS OR WARRANTIES, EITHER EXPRESS OR IMPLIED INCLUDING WITHOUT LIMITATION ANY WARRANTIES OF MERCHANTABILITY, FITNESS FOR A PARTICULAR PURPOSE OR OF ANY OTHER NATURE HEREUNDER WITH RESPECT TO INFORMATION OR THE PRODUCT TO WHICH INFORMATION REFERS.

Limitation of Liability

3M Purification will not be liable for any loss or damage arising from the use of the Product(s), whether direct, indirect, special, incidental, or consequential, regardless of the legal theory asserted, including warranty, contract, negligence or strict liability. Some states do not allow the exclusion or limitation of incidental or consequential damages, so the above limitation may not apply to you.



3M is a registered trademark of the 3M Company. LifeASSURE is a registered trademark of the 3M Company used under license.

LENNTECH

info@lennotech.com Tel. +31-152-610-900
www.lennotech.com Fax. +31-152-616-289

Data may be subject to change without further notice.

© 3M 2011. All rights reserved.

v.4 - DOC10081
LITCTLAPSA1.EU - 1211