

info@lennotech.com  
 www.lennotech.com  
 Tel. +31-15-261.09.00  
 Fax. +31-15-261.62.89



## Selection Guide Ultipleat® High Flow XL Filter System

### Description

The Ultipleat® High Flow XL filter is a large diameter, coreless, single open ended, pleated cartridge with an inside to outside flow pattern. The spacing between the pleats within the filter has been optimized to deal with applications with moderate solids loadings. The filter's unique crescent-shaped pleat geometry, combined with its large 6 inch (15.24 mm) diameter and proprietary range of available Pall filter media, allows you to use significantly fewer filters and smaller housings for high flow rate applications.

### Benefits

- Up to 50% smaller filter system possible
- Up to 40 times fewer elements to change out
- Higher flow rates per filter cartridge - up to 500 gpm (1900 lpm)
- Available in 20 inch (508 mm), 40 inch (1016 mm) and 60 inch (1524 mm) lengths
- Coreless, all plastic construction to minimize waste disposal
- Absolute rated filter medium for reproducible performance
- Inside to outside flow configuration - all debris within the filter
- Polypropylene filters are made from all FDA listed materials
- Long service life in moderate solids loadings applications.

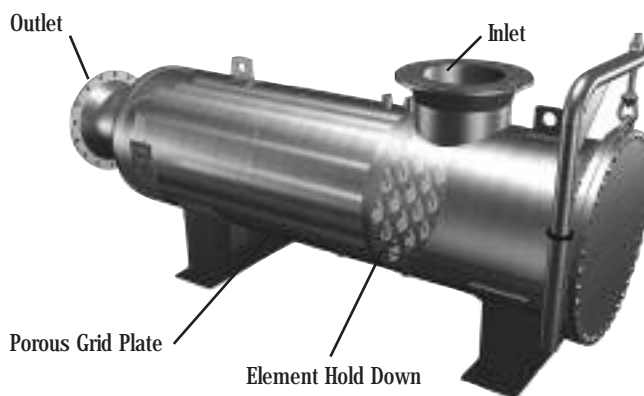

### Materials of Construction

Filter Medium Type	Filter Medium	Support/Drainage Materials	End Caps	Wrap Materials
Ultipor® CF	Glass Fiber	Polyester/Nylon	Glass Filled Acetal	Polyester and Polyamide Hotmelt

### Operating Conditions<sup>1</sup>

	Glass Fiber Medium
Maximum Differential Pressure <sup>2</sup>	50 psid at 250°F
(normal inside to outside flow)	3.44 bar at 121°C

<sup>1</sup> Maximum temperature in aqueous systems is 140°F / 60°C

<sup>2</sup> For fluids compatible with the filter element at the stated temperature.

## Ordering Information/Specifications

Filter Cartridge Part Number: HFU ▲ ● ◆

Code ▲	Filter Dimensions, Inches (nominal)	Suggested Maximum Flow Per Cartridge-GPM/LPM/MGD of Water
620	6" Diameter By 20" Long	175/663/0.25
640	6" Diameter By 40" Long	350/1325/0.5
660	6" Diameter By 60" Long	500/1900/0.7

Medium Type	Code ●	Absolute Liquid Removal Rating (Microns) at 99.9% Efficiency by Particle Count <sup>1</sup>	Element Pressure Drop <sup>2</sup> 20 inch length (PSID/GPM)/ (MBar/M3/H)	Element Pressure Drop <sup>2</sup> 40 inch length (PSID/GPM)/ (MBar/M3/H)	Element Pressure Drop <sup>2</sup> 60 inch length (PSID/GPM)/ (MBar/M3/H)
Ultipor® GF Medium-XL	HGF100	10.0	0.0029/0.88	0.0014/0.425	0.001/0.304

<sup>1</sup> The test procedure used is an adaptation of ISO 4572, modified to determine the micron size above which particles are quantitatively removed.

<sup>2</sup> Pressure drop in PSID per GPM for the cartridge length shown. Multiply this value by the total system flow to determine the aqueous pressure drop. Next for fluids other than water, multiply this value by the fluids viscosity at the operating temperature in centipoise. This value is the pressure drop across the Ultiplex High Flow filter(s) only; it must be added to the pressure drop due to the Ultiplex High Flow filter housing.

Code-Filter O-Ring ◆	Material
H13 (Standard for glass fiber filters)	Buna N
H13U <sup>1</sup>	Buna N U-Cup
J (Standard for polypropylene filters)	Ethylene Propylene
JU <sup>1</sup>	Ethylene Propylene U-Cup
H4	Silicone
H	Fluorocarbon Elastomer

<sup>1</sup> The U-Cup seal should be deployed in those applications where ease of element removal is of paramount concern.

## Housing Design

Three configurations are available: horizontal, vertical and centerpipe design.

The in-line horizontal configuration eliminates the need for a platform, or ladder, to remove the filters from the housing.

Vertical vessels may be more appropriate when floor space is limited. However, a platform may be needed to easily remove the elements.

In both the standard horizontal and vertical configurations, the inlet pipe is located between the filter element tubesheet and housing lid. The larger the vessel diameter, the longer the distance to reach in and remove the elements from the vessel. In a centerpipe vessel the housing lid is closer to the filter tubesheet. When the lid is opened the filters are easily accessible for installation and removal. Centerpipe vessels are larger in diameter, and more costly.

- Designed to the ASME, section VIII, division 1 code
- Maximum differential pressure across tubesheet: 75 psid (5.17 bar) maximum
- Standard housing gasket: spiral wound 304 stainless steel mineral fiber
- Carbon steel exterior surfaces: sandblasted and coated with an inorganic zinc
- Vent and drains: 1 inch FNPT
- Corrosion allowance: 1/8 inch

## Housing Ratings

Vessel Material	Tubesheet and Hold Down Plate Material of Construction	Pressure Rating in Psig/Bar g at 140°F / 60°C
Carbon steel	304 stainless steel	275 psig (18.95 bar)
304 stainless steel	304 stainless steel	259 psig (17.85 bar)
304L stainless steel	304L stainless steel	216 psig (14.89 bar)
316 stainless steel	316 stainless steel	261 psig (17.99 bar)
316L stainless steel	316L stainless steel	216 psig (14.89 bar)

### Filter Installation and Filter Seal Mechanism

To install a filter element, remove the element hold down plate by lifting it off the locating pins. Lubricate the O-ring on the open-end of the filter with a compatible fluid, and slide the closed end of the filter into the perforated cage, which is welded to the tubesheet. Seat the elements in place by pressing down on the open-end of the filter until the element is snug in the tubesheet. This provides a seal between the filter and housing via the filter O-ring. The open-end cap must be below the tubesheet surface. After

installing all the filter cartridges, reinstall and secure the element hold down plate by guiding it over the locating pins on the tubesheet. The purpose of the hold down plate is to prevent the elements from becoming dislodged in the event of reverse flow.

A filter element tool is provided with each housing to aid with the installation and removal of the filter cartridges. This tool eliminates the need for an operator to reach within the filter vessel to either remove or install filters.

Figure 1: Ultipleat High Flow Horizontal Housings (Aqueous Housing Pressure Drop - PSID)

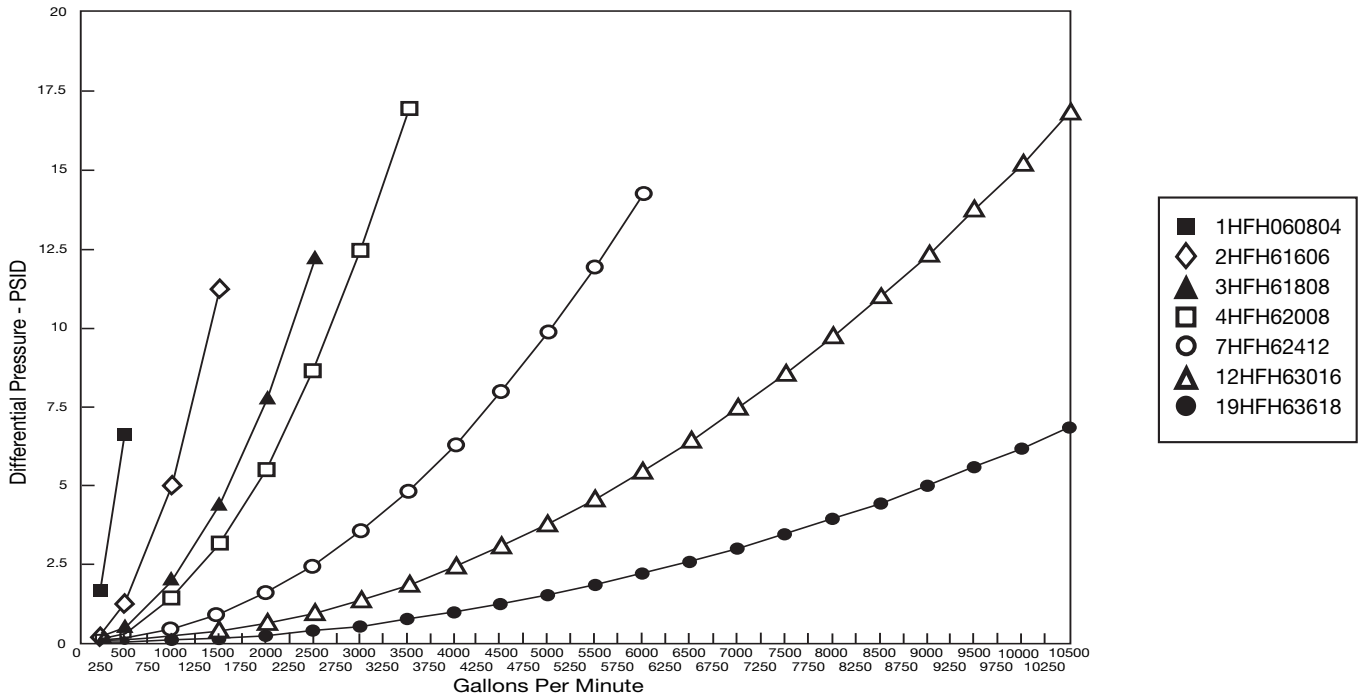

## Ordering Information-Standard Horizontal and Vertical Housings

Part Number	No. Of Filters	Rated Flow Per Housing- GPM/LPM 60" Long Filter	Nominal Housing Diameter (In/mm) (D)	Inlet/Outlet Flange Diameter (In/mm)	Maximum Horizontal Housing Overall Length (In/mm) (L)	Horizontal Housing Height (In/mm) (H)	Distance Between Housing and Lid and Tubesheet (In/mm)	Housing Weight Empty (Lbs/KG)	Housing Weight Full Of Water (Lbs/KG)	Housing Cover Swing Opening (In/mm)
1HF ■ ● 0804F1 ▲ ◆	1	500/1893	8 ⅝ /219.1	4/101.6	89/2261	32/817	14.5/368.3	471/214	621/282	9/228.6
2HF ■ ● 1606F1 ▲ ◆	2	1000/3785	16/406.4	6/152.4	100/2527	40/1023	22.7/576.3	1172/532	1771/803	25.77/654.6
3HF ■ ● 1808F1 ▲ ◆	3	1500/5680	18/457.2	8/203.2	104/2642	43/1093	26.2/665.2	1583/718	2384/1081	27.28/692.8
4HF ■ ● 2008F1 ▲ ◆	4	2000/7570	20/508	8/203.2	105/2654	46/1175	26.38/669.6	2087/947	3048/1382	29.77/756.3
7HF ■ ● 2412F1 ▲ ◆	7	3500/13248	24/609.6	12/304.8	112/2832	59/1487	31.88/809.6	3250/1474	4762/2160	34.28/870.6
12HF ■ ● 3016F1 ▲ ◆	12	6000/22710	30/762	16/406.4	121/3073	58/1480	38.69/982.7	4670/2118	7306/3314	37.99/964.9
19HF ■ ● 3620F1 ▲ ◆	19	9500/35958	36/914.4	20/508	129/3264	68/1718	43.37/1101.6	7060/3202	11121/5045	44.83/1138.8

## Ordering Information - Horizontal Orientation, Centerpipe Designed Housings

Part Number	No. Of Filters	Rated Flow Per Housing- GPM/LPM 60" Long Filter	Nominal Housing Diameter (In/mm) (D)	Inlet/Outlet Flange Diameter (In/mm)	Maximum Horizontal Housing Overall Length (In/mm) (L)	Horizontal Housing Height (In/mm) (H)	Distance Between Housing and Lid and Tubesheet (In/mm)	Housing Weight Empty (Lbs/KG)	Housing Weight Full Of Water (Lbs/KG)	Housing Cover Swing Opening (In/mm)
7HF ■ C ● 2808F1 ▲ ◆	7	3500/13248	28/711	8/203.2	104.3/2648	57/1448	4.9/124	4056/1840	6229/2825	36/914
8HF ■ C ● 3012F1 ▲ ◆	8	4000/15140	30/762	12/304	117.6/2988	58 ¼ /1480	6.1/154	4707/2135	7348/3333	40.06/1018

Code	Housing Configuration
■	
H	Horizontal
V	Vertical

Code	Housing Metallurgy
▲	
285	Carbon Steel Vessel, 304 Stainless Steel Tubesheet
S3	304L Stainless Steel
S8	304 Stainless Steel
L3	316L Stainless Steel
L8	316 Stainless Steel

Code	Nominal Cartridge Length (Inches/mm)
●	
2	20/508
4	40/1016
6	60/1524

Code	Optional Outlet Style Horizontal Housings
◆ <sup>1</sup>	
XU	Upper Outlet Location
XL	Lower Outlet Location

<sup>1</sup> If the housing is to be used as a prefilter to a horizontal liquid/liquid coalescer, then the vessel should be ordered using the XU or XL option for the outlet location. The orientation of the outlet should be the same as that of the sump on the coalescer. In this way no buildup of coalesced liquid will occur in the prefilter.

## Horizontal Housings

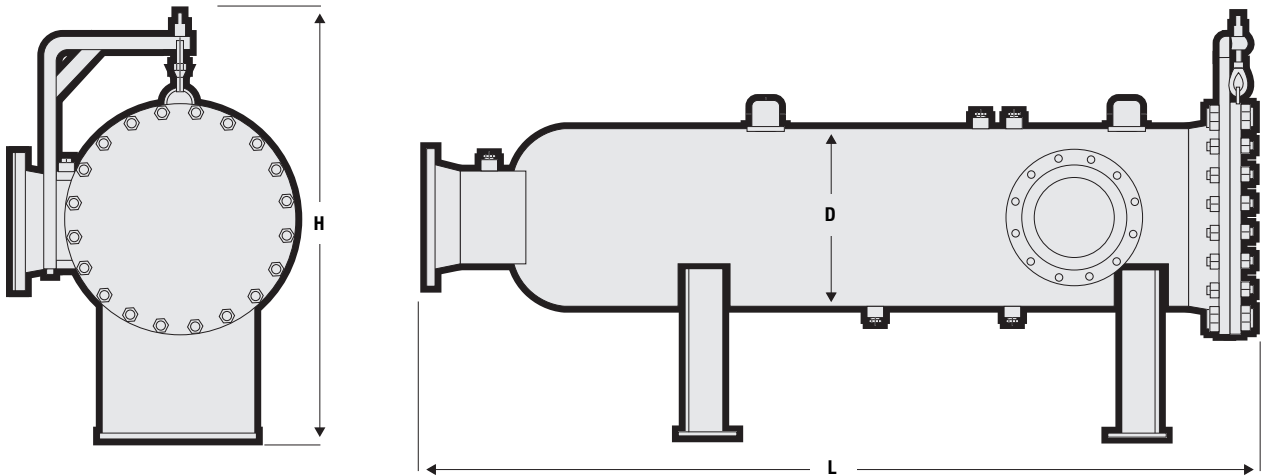

## Horizontal Housings, Centerpipe Design

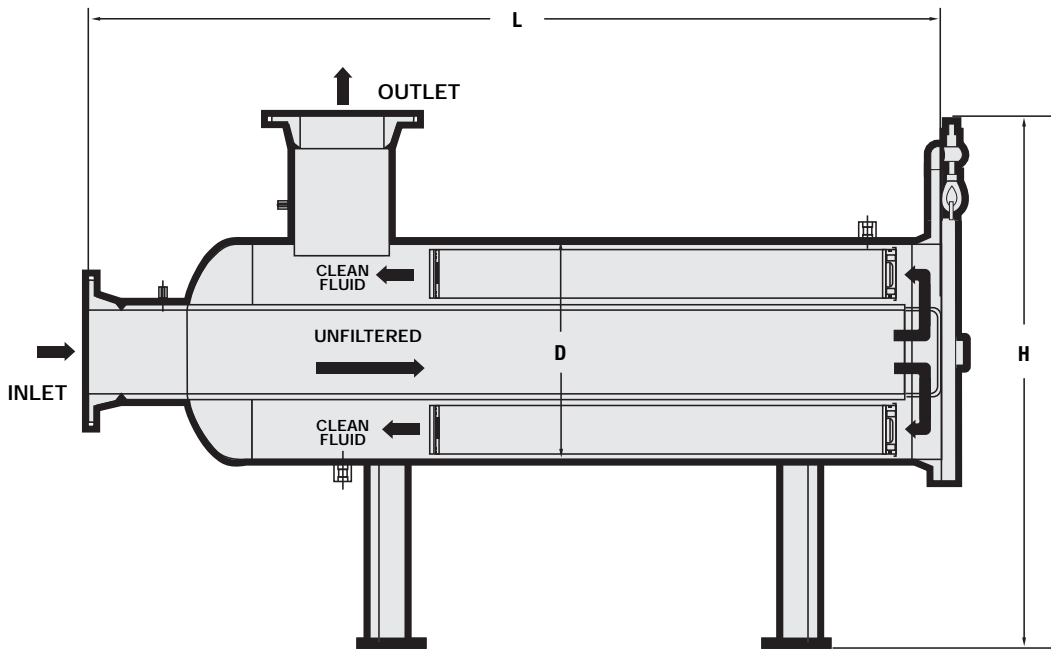

## Ultipleat High Flow Filter System Reduces Costs

Begin reducing your capital and operating costs today. Contact your local Pall distributor, or call Pall directly for an Ultipleat High Flow system quotation.

**LENNTECH**

info@lenntech.com

www.lenntech.com

Tel. +31-15-261.09.00

Fax. +31-15-261.62.89

Pall Corporation has offices and plants throughout the world in locations including: Argentina, Australia, Austria, Belgium, Brazil, Canada, China, France, Germany, India, Indonesia, Ireland, Italy, Japan, Korea, Malaysia, Mexico, the Netherlands, New Zealand, Norway, Poland, Puerto Rico, Russia, Singapore, South Africa, Spain, Sweden, Switzerland, Taiwan, Thailand, United Kingdom, United States, and Venezuela. Distributors are located in all major industrial areas of the world.

© Copyright 1999, 2006 Pall Corporation. Pall and  are trademarks of Pall Corporation. ® Indicates a Pall trademark registered in the USA. Filtration. Separation. Solution.<sup>SM</sup> is a service mark of Pall Corporation.