

MSE3 cpl. 1x200-240V, 1.85kW Grundfos pump 96160857



Thank you for your interest in our products. Please contact us for more information, or visit our website

<https://www.lenntech.com/grundfos/MS300/96160857/MSE-3.html>

info@lenntech.com

tel. +31 152 610 900

fax. +31 152 616 289

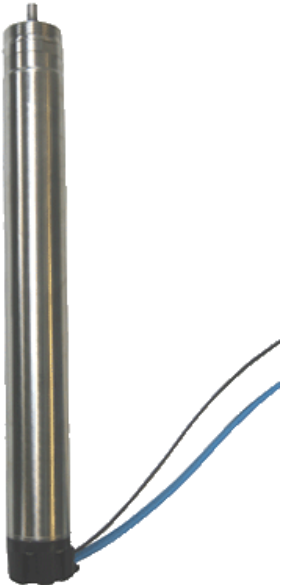
Position	Qty.	Description
	1	<p data-bbox="320 163 399 194">MSE 3</p>  <p data-bbox="711 871 1193 898" style="text-align: center;">Note! Product picture may differ from actual product</p> <p data-bbox="320 904 1406 1016">Product No.: On request The motor is a single-phase motor of the permanent magnet rotor type ensuring optimum efficiency within a wide load range. The motor is fitted with a replaceable end cover with socket.</p> <p data-bbox="320 1048 746 1106">Liquid: Max liquid t at 0.15 m/sec: 35 °C</p> <p data-bbox="320 1137 815 1196">Technical: Approvals on motor nameplate: CE,UL,CUL</p> <p data-bbox="320 1227 887 1344">Materials: Motor: Stainless steel DIN W.-Nr. 1.4301 AISI 304</p> <p data-bbox="320 1375 756 1433">Installation: Maximum ambient pressure: 15 bar</p> <p data-bbox="320 1464 852 1850">Electrical data: Motor type: MSE3 Power input - P1: 2.54 kW Rated power - P2: 1.85 kW Mains frequency: 50 Hz Rated voltage: 1 x 200-240 V Rated current: 12.3 A Power factor: 1.00 Rated speed: 10700 rpm Moment of inertia: 2330000 kg m² Start. method: direct-on-line Enclosure class (IEC 34-5): IP68 Insulation class (IEC 85): F</p> <p data-bbox="320 1881 756 1939">Others: Net weight: 4.6 kg</p>

Description	Value
General information:	
Product name:	MSE 3
Product No:	On request
EAN number:	On request
Technical:	
Approvals on motor nameplate:	CE,UL,CUL
Model:	E
Materials:	
Motor:	Stainless steel
	DIN W.-Nr. 1.4301
	AISI 304
Installation:	
Maximum ambient pressure:	15 bar
Liquid:	
Max liquid t at 0.15 m/sec:	35 °C
Electrical data:	
Motor type:	MSE3
Power input - P1:	2.54 kW
Rated power - P2:	1.85 kW
Mains frequency:	50 Hz
Rated voltage:	1 x 200-240 V
Rated current:	12.3 A
Power factor:	1.00
Rated speed:	10700 rpm
Moment of inertia:	2330000 kg m ²
Axial load max:	100 kg
Start. method:	direct-on-line
Enclosure class (IEC 34-5):	IP68
Insulation class (IEC 85):	F
Motor protec:	Y
Thermal protec:	internal
Controls:	
CU 300/CU 301:	communication with CU 300/CU 301 possible
Others:	
Net weight:	4.6 kg

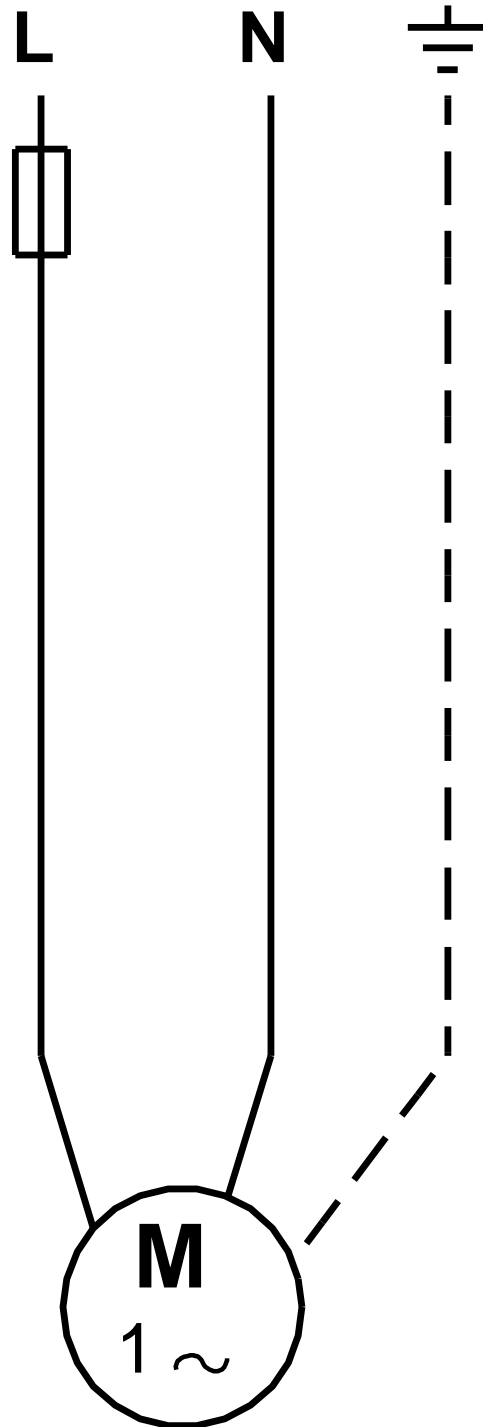

Exploded view

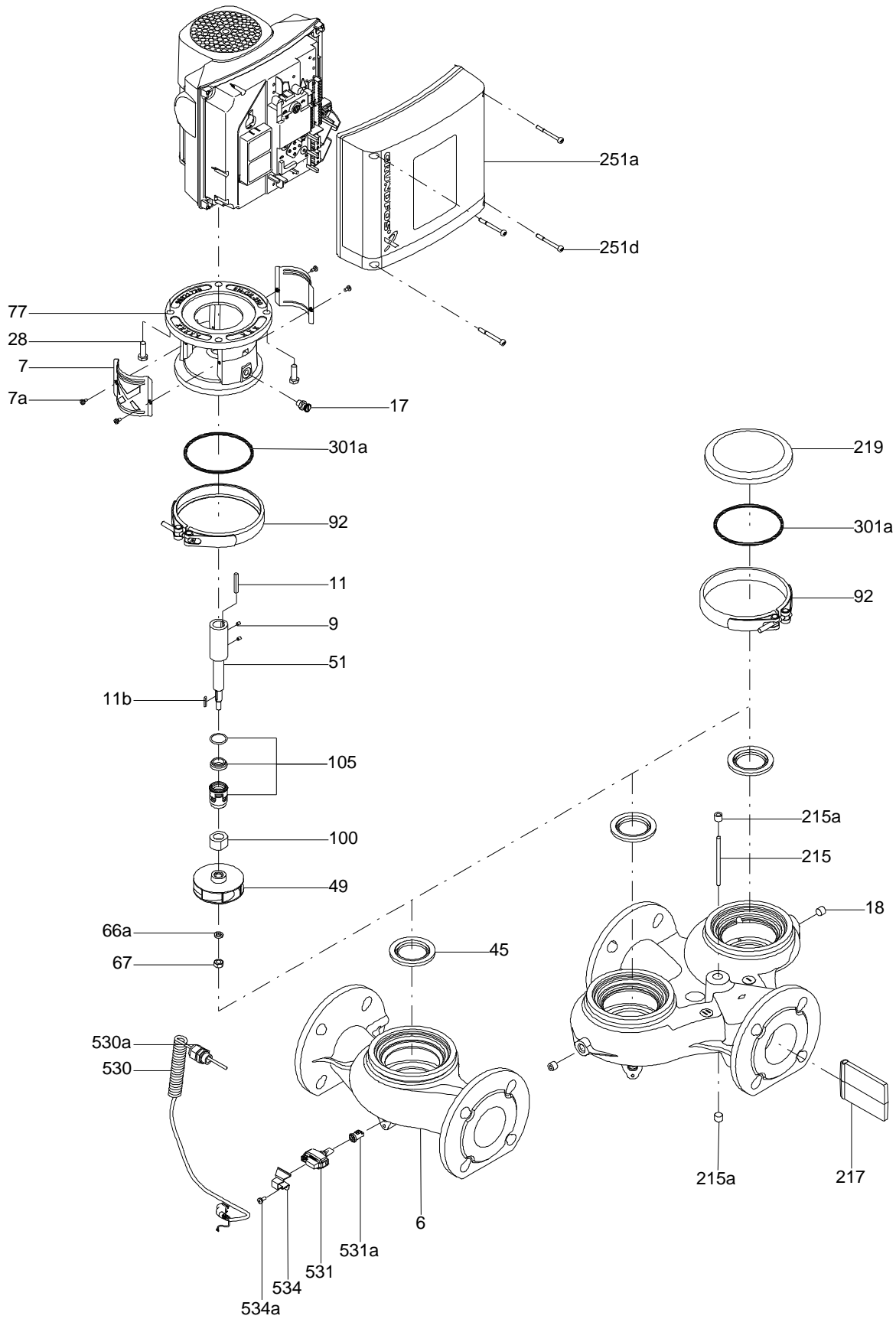

Sectional drawing (TM058200 for TPE2,TPE3)

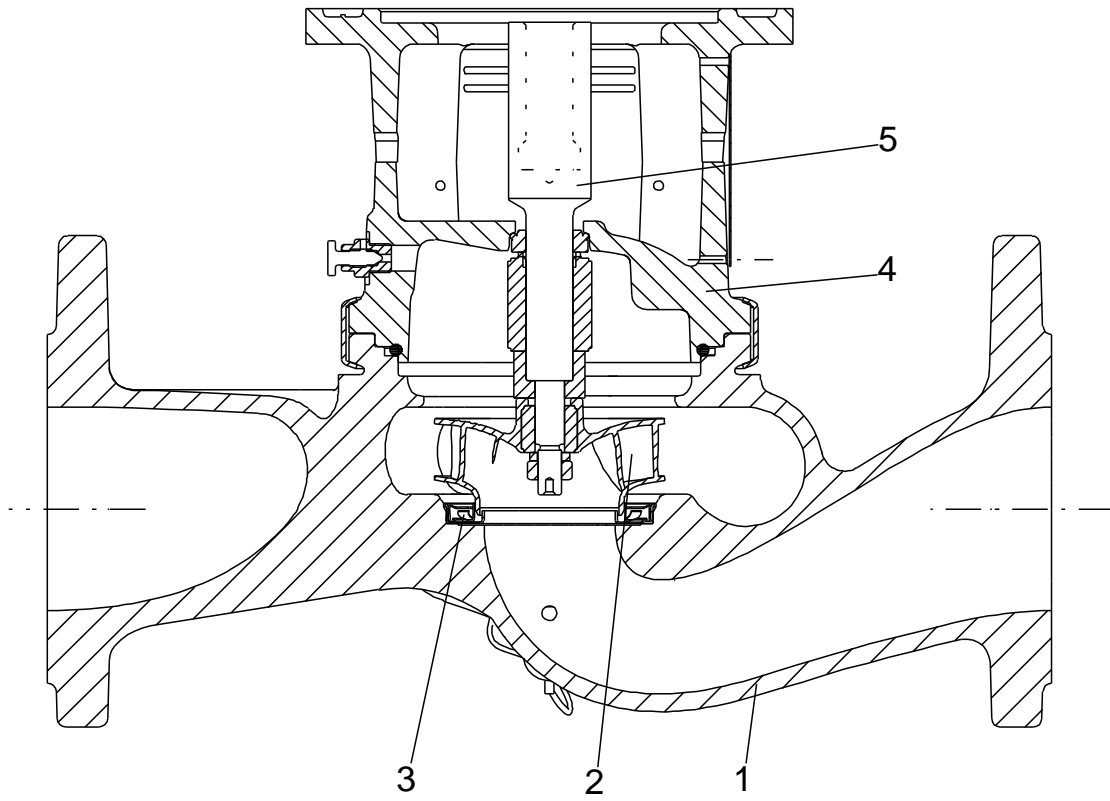

TM058200

Exploded view (TM057026 for MGE model H/I)

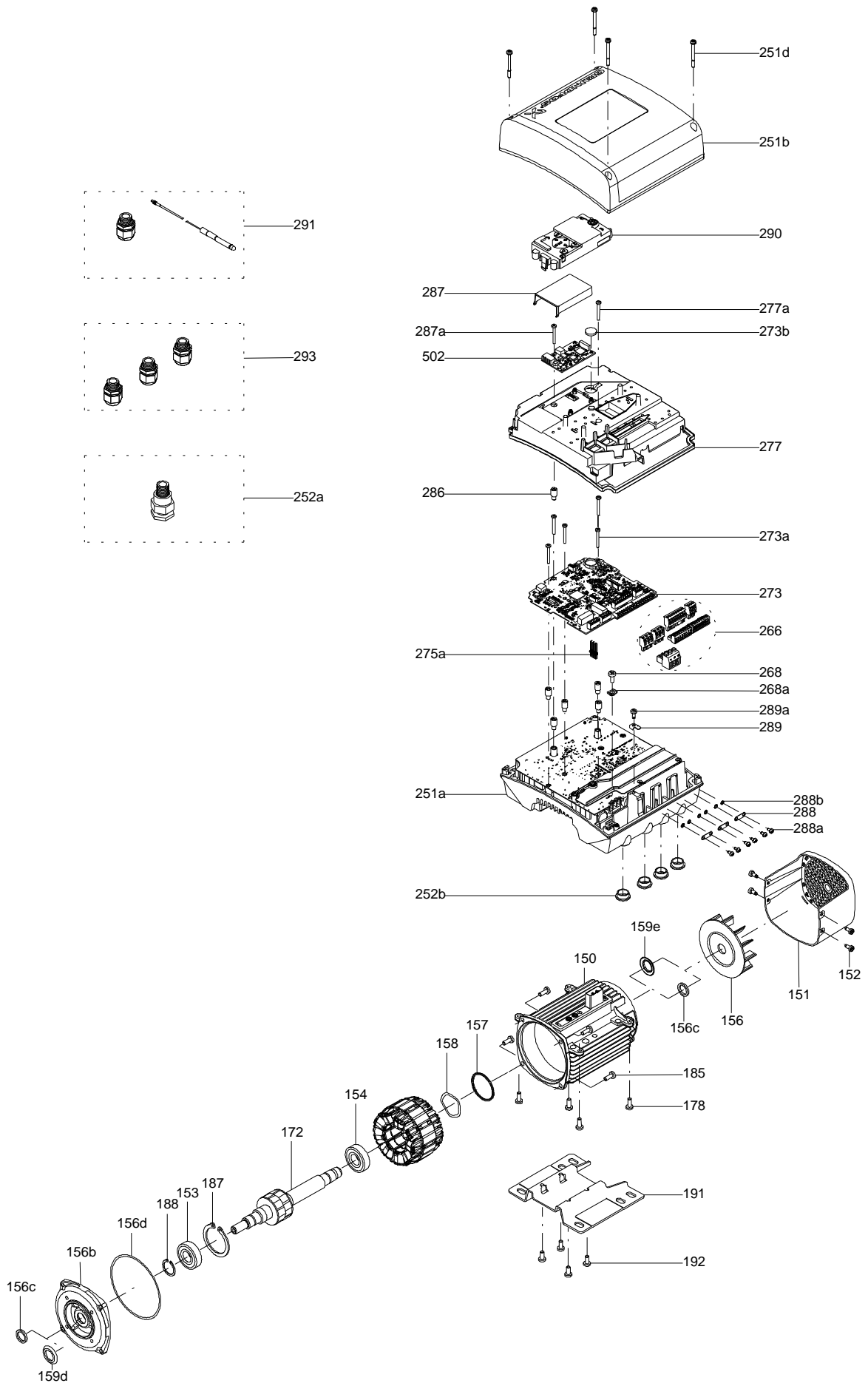

Parts list MSE 3, Product No. On request
Valid from 3.12.2012 (1249)

Pos	Description	Annotation	Données de classification	Référence	Quantité	Unité
	Motor liquid				0	L
220	Power cable				1	pcs
- 250	Screw				4	pcs
18a	Pan head tapping screw				2	
250	Pan head screw				4	
- 250	Screw				1	pcs
18a	Pan head tapping screw				2	
250	Pan head screw				4	

Disclaimer: The information about the Grundfos pump in this document may be outdated.

Data may be subject to alterations without further notice.

Please contact us to verify the data above is still accurate/up-to-date.

All information is copyright Grundfos.



info@lenntech.com

<https://www.lenntech.com>

tel. +31 152 610 900

fax. +31 152 616 289