

CRN1S-3 A-FGJ-G-V-HQQV 3x230/400 50HZ Grundfos pump 96515930



Thank you for your interest in our products. Please contact us for more information, or visit our website

<https://www.lenntech.com/grundfos/CRN1S/96515930/CRN-1S-3-A-FGJ-G-V-HQQV.html>

info@lenntech.com

tel. +31 152 610 900

fax. +31 152 616 289

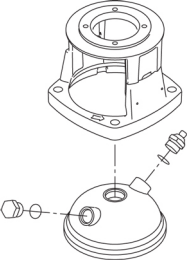
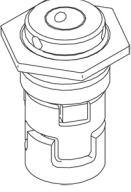
Position	Qty.	Description
	1	<p data-bbox="323 163 651 197">CRN 1S-3 A-FGJ-A-V-HQQV</p>  <p data-bbox="323 488 603 521">Product No.: On request</p> <p data-bbox="323 544 1420 622">Vertical, multistage centrifugal pump with inlet and outlet ports on same the level (inline). Pump materials in contact with the liquid are in high-grade stainless steel. Power transmission is via a rigid split coupling. Pipe connection is via combined DIN-ANSI-JIS flanges.</p> <p data-bbox="323 656 1053 689">The pump is fitted with a 3-phase, fan-cooled asynchronous motor.</p> <p data-bbox="323 723 638 757">Further product details</p> <p data-bbox="323 757 1449 857">Steel, cast iron and aluminium components have an epoxy-based coating made in a cathodic electro-deposition (CED) process. CED is a high-quality dip-painting process where an electrical field around the products ensures deposition of paint particles as a thin, well-controlled layer on the surface. An integral part of the process is a pretreatment. The entire process consists of these elements:</p> <ol data-bbox="323 869 813 992" style="list-style-type: none"> 1) Alkaline-based cleaning. 2) Zinc phosphating. 3) Cathodic electro-deposition. 4) Curing to a dry film thickness 18-22 my m. <p data-bbox="323 992 1029 1014">The colour code for the finished product is NCS 9000/RAL 9005.</p> <p data-bbox="323 1048 406 1081">Pump</p> <p data-bbox="323 1081 1444 1160">The pump head and flange for motor mounting is made in one piece (cast iron). The pump head cover is a separate component (stainless steel). The pump head has a combined 1/2" priming plug and vent screw.</p>  <p data-bbox="323 1462 1428 1563">The pump is fitted with a balanced O-ring seal unit with a rigid torque-transmission system. This seal type is assembled in a cartridge unit which makes replacement safe and easy. Due to the balancing, this seal type is suitable for high-pressure applications. The cartridge construction also protects the pump shaft from possible wear from a dynamic O-ring between pump shaft and shaft seal.</p> <p data-bbox="323 1574 470 1608">Primary seal:</p> <ul data-bbox="355 1608 917 1664" style="list-style-type: none"> • Rotating seal ring material: silicon carbide (SiC) • Stationary seat material: silicon carbide (SiC) <p data-bbox="323 1664 1428 1720">This material pairing is used where higher corrosion resistance is required. The high hardness of this material pairing offers good resistance against abrasive particles.</p> <p data-bbox="323 1720 893 1753">Secondary seal material: FKM (fluorocarbon rubber)</p> <p data-bbox="323 1753 1428 1809">FKM has excellent resistance to oils and chemicals. Above 90 °C, FKM should only be used in media without water.</p>  <p data-bbox="323 2056 829 2089">The shaft seal is screwed into the pump head.</p>

Position	Qty.	Description
		<p>The pump has a stainless-steel base mounted on a separate base plate. This base and base plate are kept in position by the tension of the staybolts which hold the pump together. The outlet side of the base has a combined drain plug and bypass valve. The pump is secured to the foundation by four bolts through the base plate. The flanges and base are cast in one piece and prepared for connection by means of DIN, ANSI or JIS.</p> <p>Motor</p> <p>The motor is a totally enclosed, fan-cooled motor with principal dimensions to IEC and DIN standards. The motor is flange-mounted with tapped-hole flange (FT).</p> <p>Motor-mounting designation in accordance with IEC 60034-7: IM B 14 (Code I) / IM 3601 (Code II). Electrical tolerances comply with IEC 60034. The motor efficiency is classified as IE3 in accordance with IEC 60034-30-1. The motor does not incorporate motor protection and must be connected to a motor-protective circuit breaker which can be manually reset. The motor-protective circuit breaker must be set according to the rated current of the motor (I1/1).</p> <p>Technical data</p> <p>Controls: Frequency converter: NONE</p> <p>Liquid: Pumped liquid: Water Liquid temperature range: -20 .. 90 °C Liquid temperature during operation: 20 °C Density: 998.2 kg/m³</p> <p>Technical: Rated flow: 0.9 m³/h Rated head: 12.8 m Pump orientation: Vertical Shaft seal arrangement: Single Code for shaft seal: HQQV Approvals on nameplate: CE, EAC Curve tolerance: ISO9906:2012 3B</p> <p>Materials: Base: Stainless steel EN 1.4408 AISI 316 Impeller: Stainless steel EN 1.4401 AISI 316 Bearing: SIC</p> <p>Installation: Maximum ambient temperature: 40 °C Maximum operating pressure: 25 bar Max pressure at stated temp: 25 bar / 90 °C 25 bar / -20 °C Type of connection: DIN / ANSI / JIS Size of inlet connection: DN 25/32 1 1/4 inch Size of outlet connection: DN 25/32 1 1/4 inch Pressure rating for pipe connection: PN 25 Flange rating inlet: 300 lb Flange size for motor: FT85</p> <p>Electrical data: Motor standard: IEC Motor type: 71A IE Efficiency class: IE3 Rated power - P2: 0.37 kW Power (P2) required by pump: 0.37 kW Mains frequency: 50 Hz</p>

Position	Qty.	Description
		<p>Rated voltage: 3 x 220-240D/380-415Y V</p> <p>Rated current: 1.74/1.00 A</p> <p>Starting current: 490-530 %</p> <p>Cos phi - power factor: 0.80-0.70</p> <p>Rated speed: 2850-2880 rpm</p> <p>Efficiency: IE3 73,8%</p> <p>Motor efficiency at full load: 73.8 %</p> <p>Motor efficiency at 3/4 load: 79.0 %</p> <p>Motor efficiency at 1/2 load: 75.5 %</p> <p>Number of poles: 2</p> <p>Enclosure class (IEC 34-5): 55 Dust/Jetting</p> <p>Insulation class (IEC 85): F</p> <p>Others:</p> <p>Minimum efficiency index, MEI : 0.54</p> <p>Net weight: 20.8 kg</p> <p>Gross weight: 23.4 kg</p> <p>Shipping volume: 0.054 m³</p>

On request CRN 1S-3 A-FGJ-A-V-HQQV 50 Hz

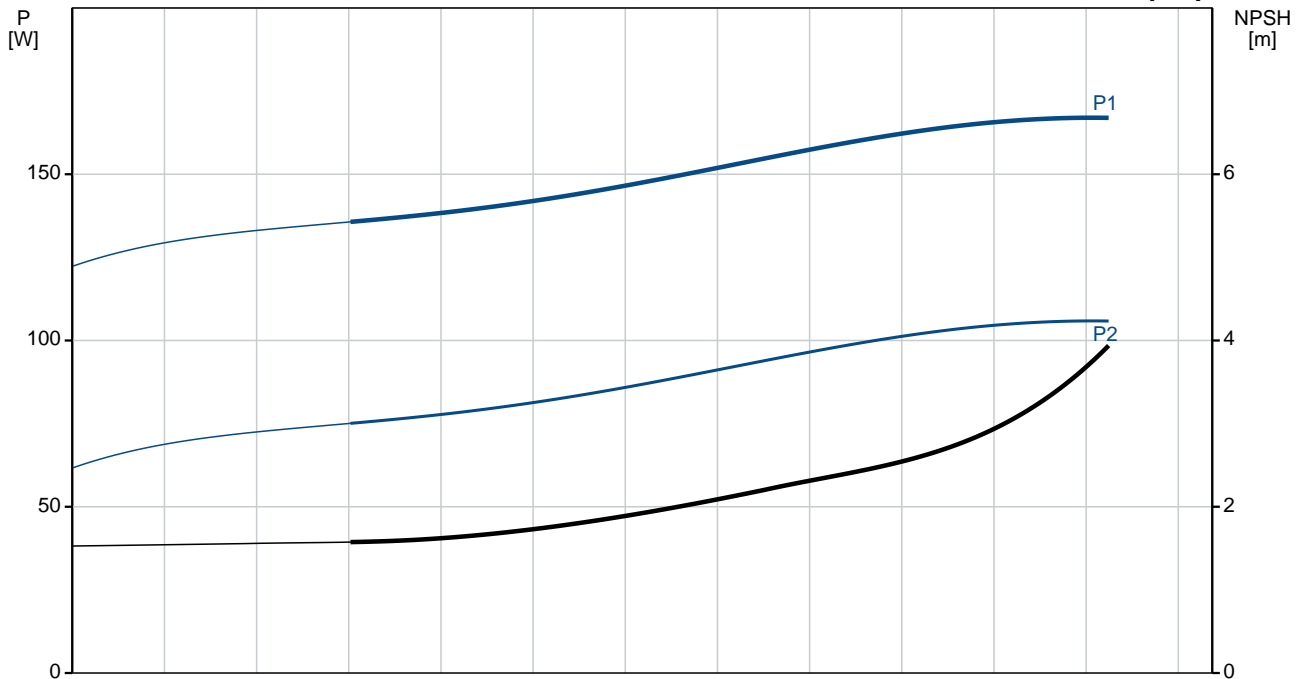
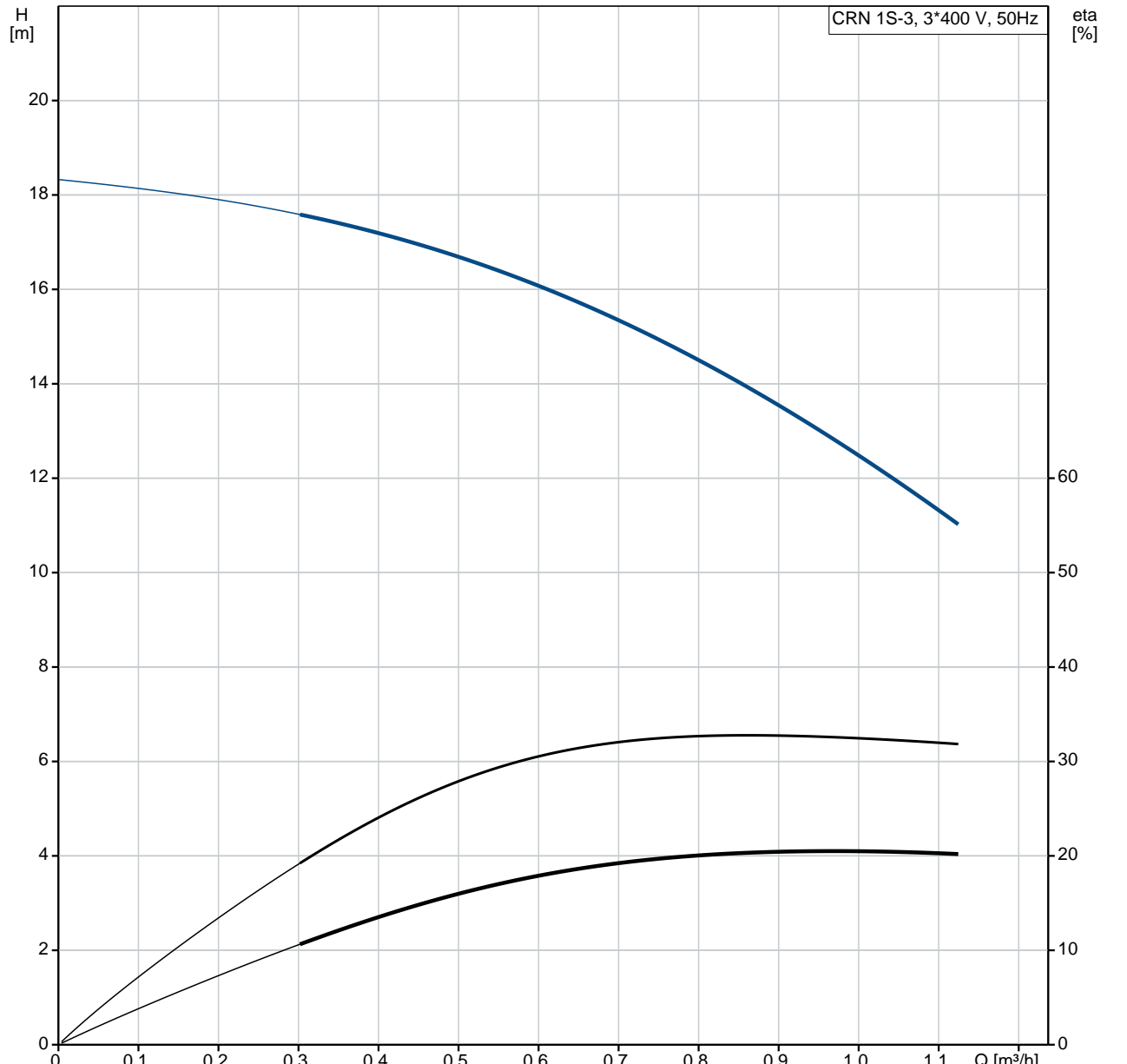

Description	Value
General information:	
Product name:	CRN 1S-3 A-FGJ-A-V-HQQV
Product No:	On request
EAN number:	On request
Technical:	
Rated flow:	0.9 m ³ /h
Rated head:	12.8 m
Stages:	3
Impellers:	3
Number of reduced-diameter impellers:	0
Low NPSH:	N
Pump orientation:	Vertical
Shaft seal arrangement:	Single
Code for shaft seal:	HQQV
Approvals on nameplate:	CE, EAC
Curve tolerance:	ISO9906:2012 3B
Pump version:	A
Model:	A
Materials:	
Base:	Stainless steel EN 1.4408 AISI 316
Impeller:	Stainless steel EN 1.4401 AISI 316
Material code:	A
Code for rubber:	V
Bearing:	SIC
Installation:	
Maximum ambient temperature:	40 °C
Maximum operating pressure:	25 bar
Max pressure at stated temp:	25 bar / 90 °C 25 bar / -20 °C
Type of connection:	DIN / ANSI / JIS
Size of inlet connection:	DN 25/32 1 1/4 inch
Size of outlet connection:	DN 25/32 1 1/4 inch
Pressure rating for pipe connection:	PN 25
Flange rating inlet:	300 lb
Flange size for motor:	FT85
Connect code:	FGJ
Liquid:	
Pumped liquid:	Water
Liquid temperature range:	-20 .. 90 °C
Liquid temperature during operation:	20 °C
Density:	998.2 kg/m ³
Electrical data:	
Motor standard:	IEC
Motor type:	71A
IE Efficiency class:	IE3
Rated power - P2:	0.37 kW
Power (P2) required by pump:	0.37 kW
Mains frequency:	50 Hz
Rated voltage:	3 x 220-240D/380-415Y V
Rated current:	1.74/1.00 A
Starting current:	490-530 %
Cos phi - power factor:	0.80-0.70
Rated speed:	2850-2880 rpm
Efficiency:	IE3 73,8%
Motor efficiency at full load:	73.8 %
Motor efficiency at 3/4 load:	79.0 %

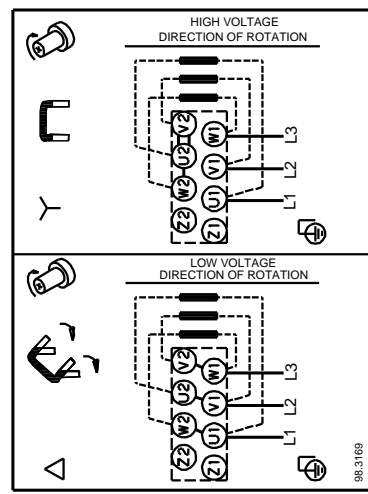
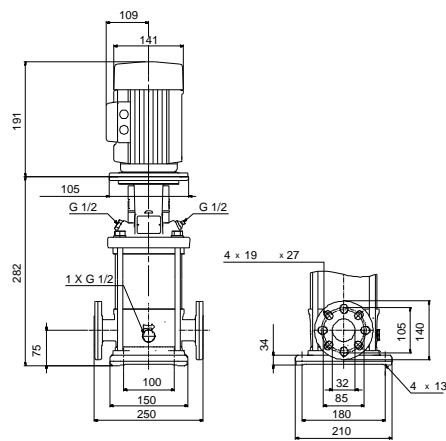
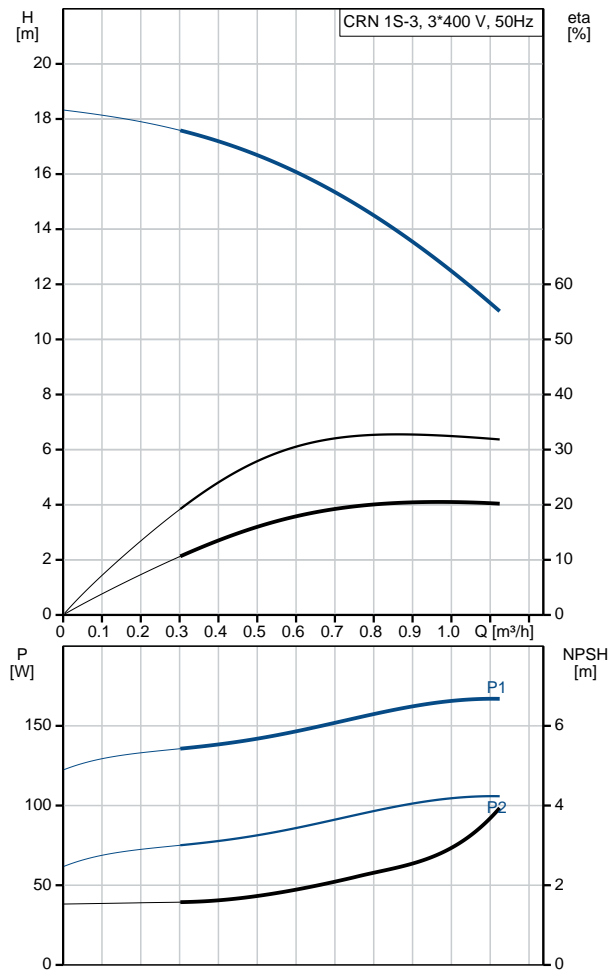

Description	Value
Motor efficiency at 1/2 load:	75.5 %
Number of poles:	2
Enclosure class (IEC 34-5):	55 Dust/Jetting
Insulation class (IEC 85):	F
Motor protec:	NONE
Motor No:	85805102
Controls:	
Frequency converter:	NONE
Others:	
Minimum efficiency index, MEI :	0.54
Net weight:	20.8 kg
Gross weight:	23.4 kg
Shipping volume:	0.054 m ³

On request CRN 1S-3 A-FGJ-A-V-HQQV 50 Hz

CRN1S-3 + 71A 0.37 kW 3*400 V, 50 Hz

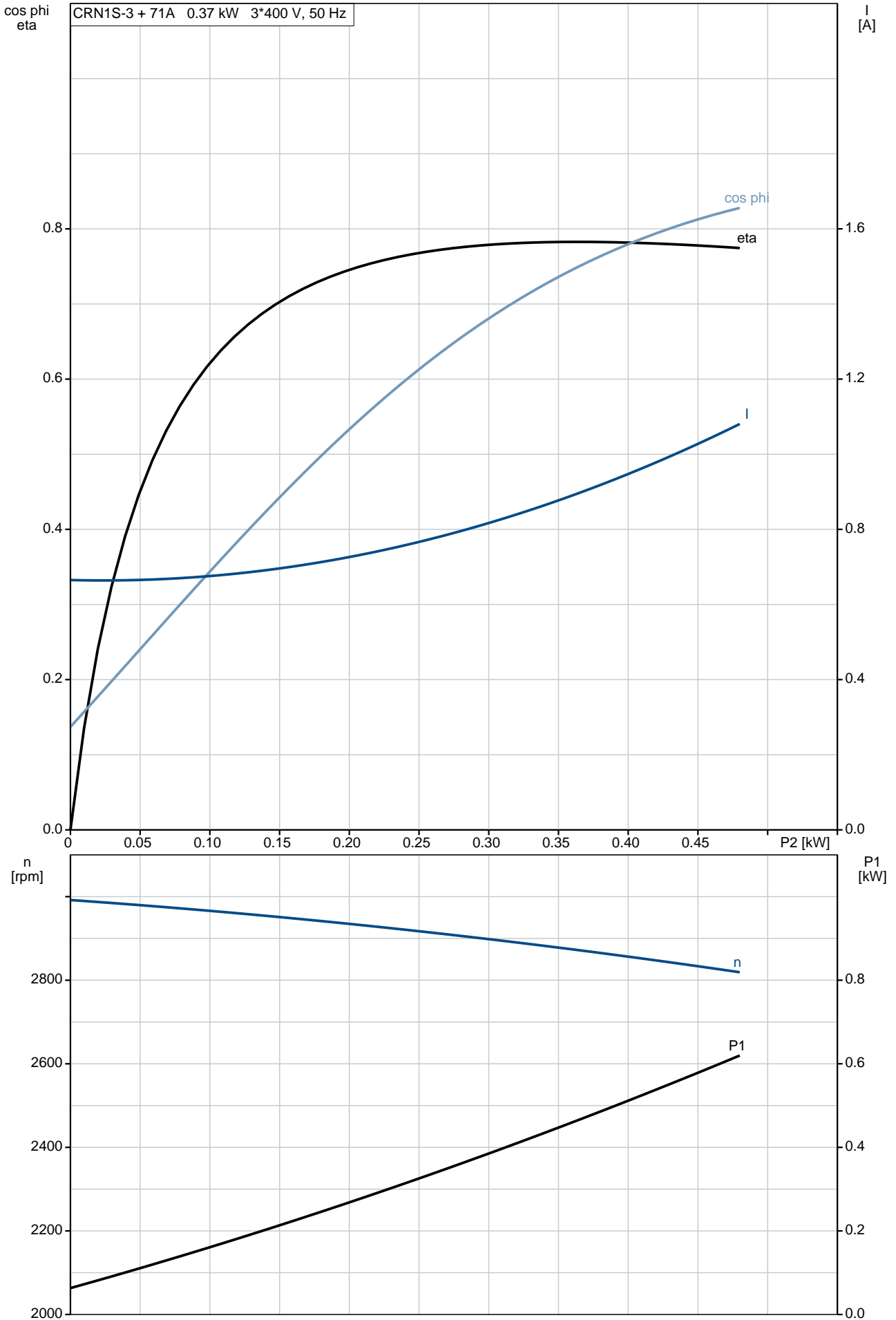

On request CRN 1S-3 A-FGJ-A-V-HQQV 50 Hz

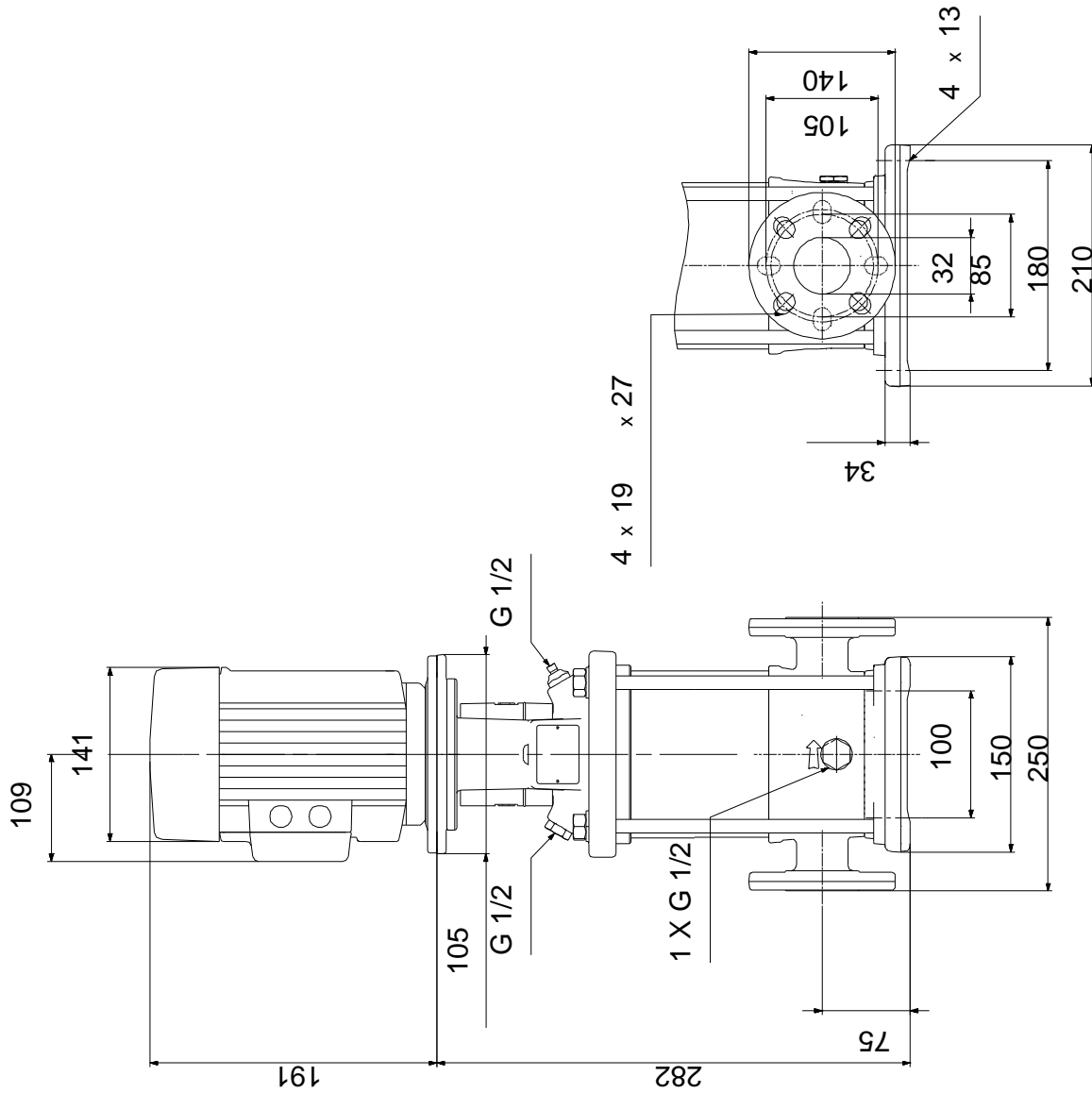

Note! All units are in [mm] unless others are stated.
 Disclaimer: This simplified dimensional drawing does not show all details.

Exploded view

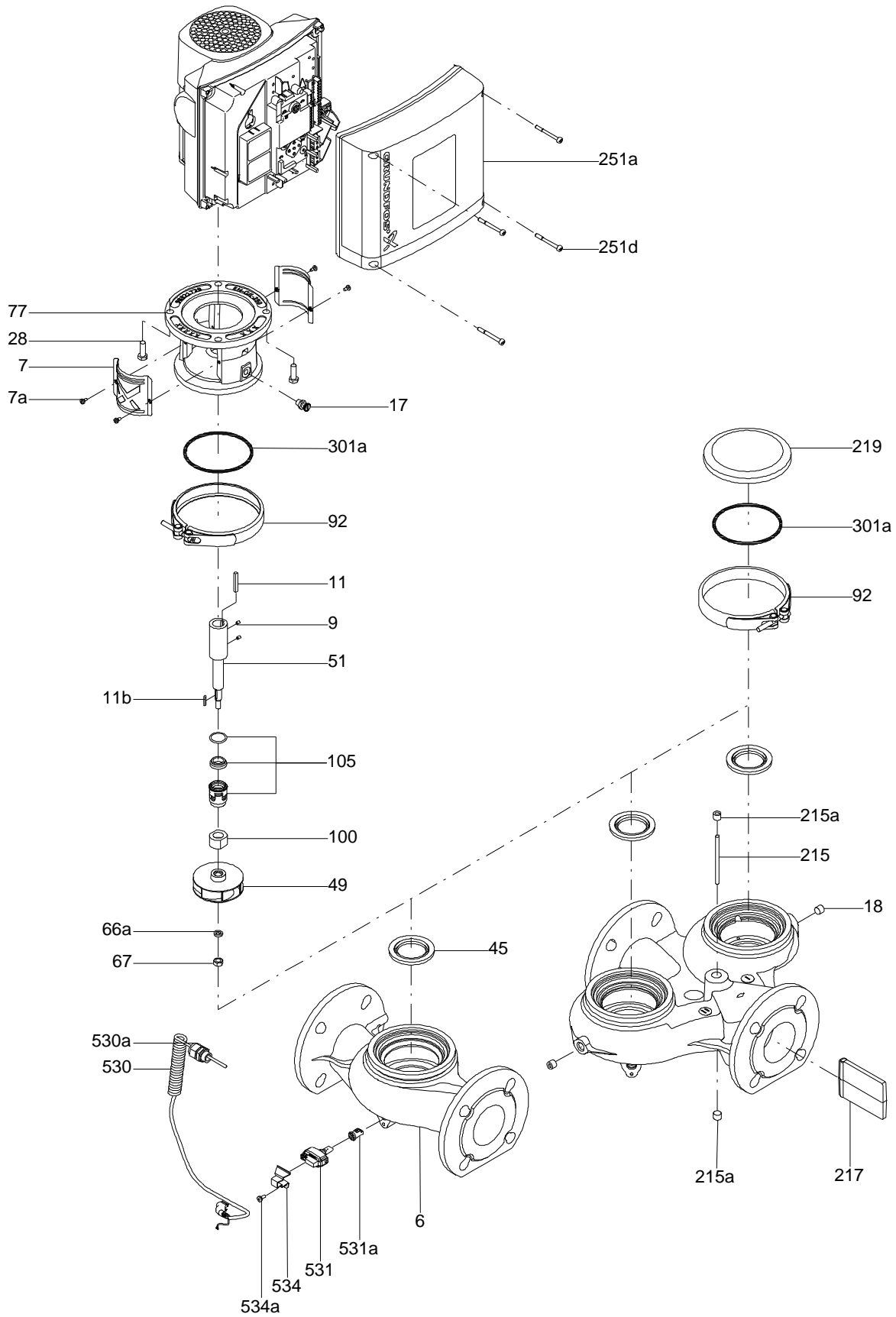

Sectional drawing (TM058200 for TPE2,TPE3)



TM058200

Exploded view (TM057026 for MGE model H/I)

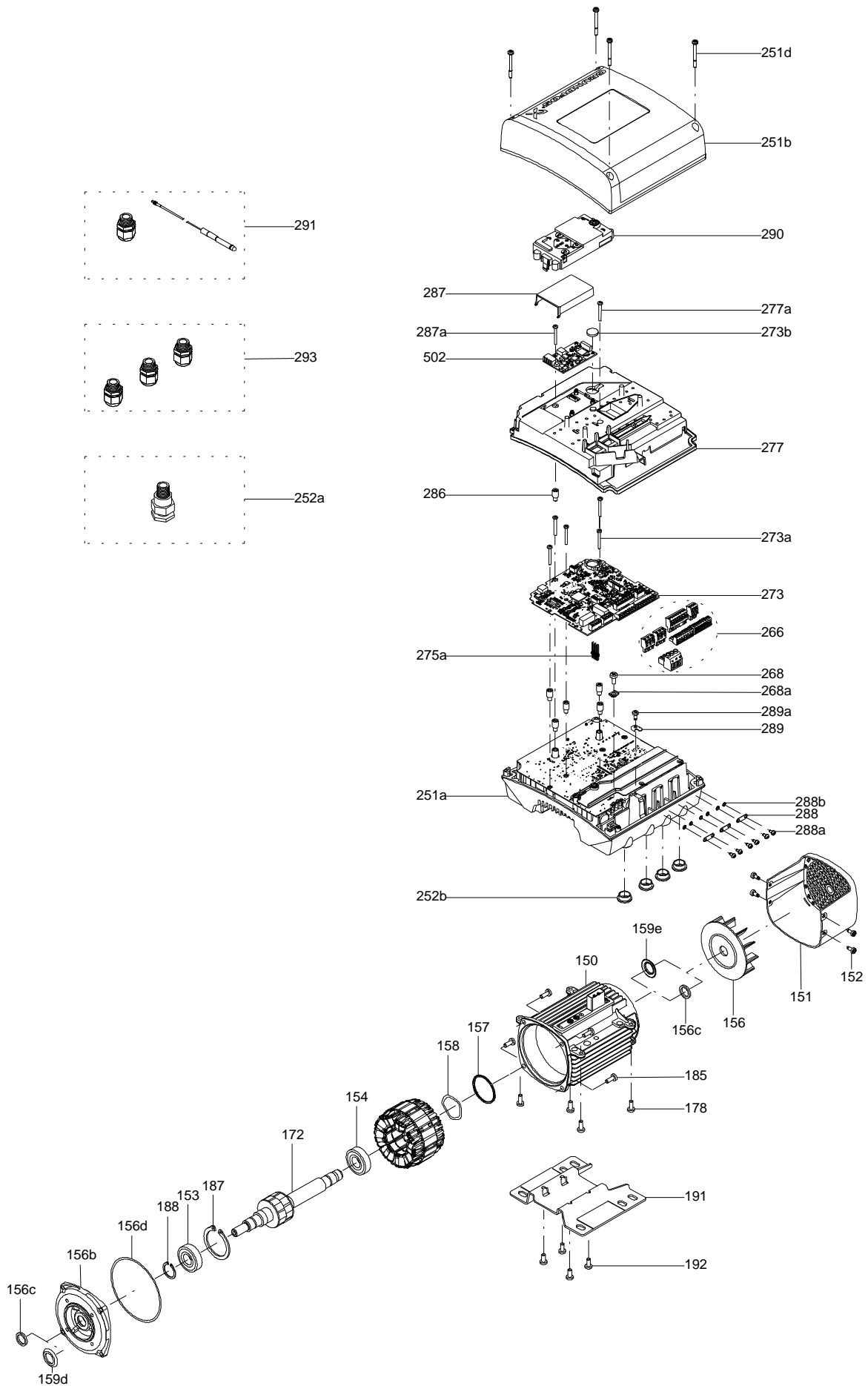

Parts list CRN 1S-3, Product No. On request
Valid from 1.1.2004 (0401)

Pos	Description	Annotation	Données de classification	Référence	Quantité	Unité
+	Motor				1	pcs
-	Base cpl.				1	pcs
6	Base				1	
56	Base plate				1	
201.a	Flange				2	
203	Lock ring				2	
-	Sealing parts				1	pcs
- 25	Drain plug w/bypass valve				1	
38	O-ring		Diameter: 16,3		1	
			Material type: FKM			
			Thickness: 2,4			
37	O-ring		Diameter: 137,5		2	
			Material type: FKM			
			Thickness: 3,3			
100	O-ring		Diameter: 16,3		2	
			Material type: FKM			
			Thickness: 2,4			
- 2	Pump head cpl.				1	pcs
2	Pump head				1	
7	Coupling guard				2	
7.a	Combi Slot Torx screw				4	
- 18	Air vent screw				1	
	Plug				1	
	Spindle				1	
23a	Plug				1	
28	Hex head screw		Length (mm): 20		4	
			Thread: M6			
60	Formed wire spring				1	
77	Pump cover				1	
- 8	Coupling				1	pcs
9	Hex socket head cap screw		Designation: DIN 912		4	
			Length (mm): 20			
			Thread: M6			
10	Shaft pin		Diameter: 5		1	
			Length (mm): 26			
10a	Coupling half				2	
26	Staybolt		Length (mm): 155		4	pcs
			Thread: M12			
36	Nut		Thread: M12		4	pcs
55	Outer sleeve				1	pcs
66a	Washer		Designation: DIN 125 A2		4	pcs
			Internal diameter: 13			
			Outer diameter: 24			
			Thickness: 2,5			
- 80	Chamber stack				1	pcs
- 4	Chamber cpl.				1	
4a	Intermediate chamber				1	
45	Neck ring				1	
65	Neck ring retainer				1	
- 4a	Chamber w. bearing cpl.				1	
4a	Intermediate chamber				1	
45	Neck ring				1	
65	Neck ring retainer				1	
- 5a	Chamber cpl.				1	
4a	Intermediate chamber				1	
45	Neck ring				1	
65	Neck ring retainer				1	
36	Lock nut		Thread: M8		1	
47a	Bearing ring, rotating				1	

Pos	Description	Annotation	Données de classification	Référence	Quantité	Unité
- 49	Impeller cpl.				3	
49	Impeller				1	
- 50a	Guide vane				1	
	Plate				1	
50b	Top plate				1	
51	Shaft, spline, cpl.				1	
64a	Spacing pipe				1	
64a	Spacing pipe		Internal diameter: 12,85		1	
			Outer diameter: 15,85			
			Length (mm): 4,50			
64c	Clamp, splined		Internal diameter: 8,5		1	
			Outer diameter: 15			
66	Wedge lock washer				1	
- 105	Shaft seal		Material type: HQQV		1	pcs
	O-ring				1	
	O-ring				1	
	O-ring				1	
	Seal driver, upper				1	
	Seal driver, lower				1	
	Spacer ring				1	
	Pipe				1	
	Plug				1	
	Plug				1	
	Compression spring				1	
	Socket set screw				3	
103	Seal ring, stationary				1	
105	Seal ring, rotating				1	
109	O-ring				1	
113	Driver				1	

Disclaimer: The information about the Grundfos pump in this document may be outdated.

Data may be subject to alterations without further notice.

Please contact us to verify the data above is still accurate/up-to-date.

All information is copyright Grundfos.



info@lenntech.com

<https://www.lenntech.com>

tel. +31 152 610 900

fax. +31 152 616 289