

## DWK.O.13.80.55.5.0D Grundfos pump 96922653



Thank you for your interest in our products. Please contact us for more information, or visit our website

<https://www.lenntech.com/grundfos/DWK000/96922653/DWK-O-13-80-55-5-0D.html>

[info@lenntech.com](mailto:info@lenntech.com)

tel. +31 152 610 900

fax. +31 152 616 289

Position	Qty.	Description
	1	<p data-bbox="320 163 571 197"><b>DWK.O.13.80.55.5.0D</b></p>  <p data-bbox="320 483 600 517">Product No.: On request</p> <p data-bbox="320 544 655 577">Submersible Contractor Pump</p> <p data-bbox="320 602 1270 636">Grundfos DWK pump is a submersible pump for dewatering and drainage applications.</p> <p data-bbox="320 660 879 781">The pump is suitable for pumping          -large quantities of underground and surface water          -drainage water at high head          -water with dirt from drainage pits</p> <p data-bbox="320 808 1342 842">The compact design makes the pump suitable for both temporary and permanent installation.</p> <p data-bbox="320 869 1449 925">The pump is cast iron, with vertical discharge port and integrated submersible 3-phase totally enclosed motor in insulation class F (155°C).</p> <p data-bbox="320 952 1214 985">The pump has a rise pipe, a double mechanical seal and semi-open impeller type</p> <p data-bbox="320 1012 1433 1068">The pump is equipped with a temperature Bi-metal sensor for motor protection in case of overheating and electrode seal sensor to detect water penetration in to the motor housing.</p> <p data-bbox="320 1095 1078 1128">The pump is fitted with suction strainer, lifting handle and 10 m cable.</p> <p data-bbox="320 1193 432 1227"><b>Controls:</b></p> <p data-bbox="320 1227 703 1261">Seal sensor: N</p> <p data-bbox="320 1288 405 1321"><b>Liquid:</b></p> <p data-bbox="320 1321 791 1355">Liquid temperature range: 0 .. 40 °C</p> <p data-bbox="320 1355 818 1388">Density: 998.2 kg/m<sup>3</sup></p> <p data-bbox="320 1415 443 1449"><b>Technical:</b></p> <p data-bbox="320 1449 775 1482">Actual impeller diameter: 174 mm</p> <p data-bbox="320 1482 703 1516">Type of impeller: O</p> <p data-bbox="320 1516 762 1550">Maximum particle size: 13 mm</p> <p data-bbox="320 1550 775 1583">Primary shaft seal: SIC-SIC</p> <p data-bbox="320 1583 914 1617">Secondary shaft seal: CERAMIC-CARBON</p> <p data-bbox="320 1617 743 1650">Max. hydraulic efficiency: 51 %</p> <p data-bbox="320 1650 756 1684">Curve tolerance: NONE</p> <p data-bbox="320 1711 437 1744"><b>Materials:</b></p> <p data-bbox="320 1744 919 1778">Pump housing: Cast iron EN1561 EN-GJL-200</p> <p data-bbox="320 1778 959 1812">Impeller: Ductile cast iron EN1563 EN-GJS-450-10</p> <p data-bbox="320 1812 919 1845">Motor: Cast iron EN1561 EN-GJL-200</p> <p data-bbox="320 1872 459 1906"><b>Installation:</b></p> <p data-bbox="320 1906 746 1939">Maximum ambient temperature: 40 °C</p> <p data-bbox="320 1939 756 1973">Pump outlet: DN 80</p> <p data-bbox="320 1973 743 2007">Maximum installation depth: 25 m</p> <p data-bbox="320 2033 496 2067"><b>Electrical data:</b></p>

Position	Qty.	Description
		<p>Rated power - P2: 5.5 kW</p> <p>Mains frequency: 50 Hz</p> <p>Rated voltage: 3 x 380-415 V</p> <p>Voltage tolerance: +5/-5 %</p> <p>Max starts per. hour: 30</p> <p>Rated current: 10.5 A</p> <p>Rated current at 3/4 load: 8 A</p> <p>Rated current at 1/2 load: 5.9 A</p> <p>Cos phi - power factor: 0.91</p> <p>Cos phi - p.f. at 3/4 load: 0.88</p> <p>Cos phi - p.f. at 1/2 load: 0.82</p> <p>Rated speed: 2850 rpm</p> <p>Motor efficiency at full load: 88.2 %</p> <p>Motor efficiency at 3/4 load: 88.8 %</p> <p>Motor efficiency at 1/2 load: 88.2 %</p> <p>Number of poles: 2</p> <p>Start. method: direct-on-line</p> <p>Enclosure class (IEC 34-5): IP68</p> <p>Insulation class (IEC 85): F</p> <p>Explosion proof: no</p> <p>Length of cable: 10 m</p> <p>Cable type: TP90/TP90</p> <p><b>Others:</b></p> <p>Net weight: 110 kg</p>

# On request DWK.O.13.80.55.5.0D 50 Hz

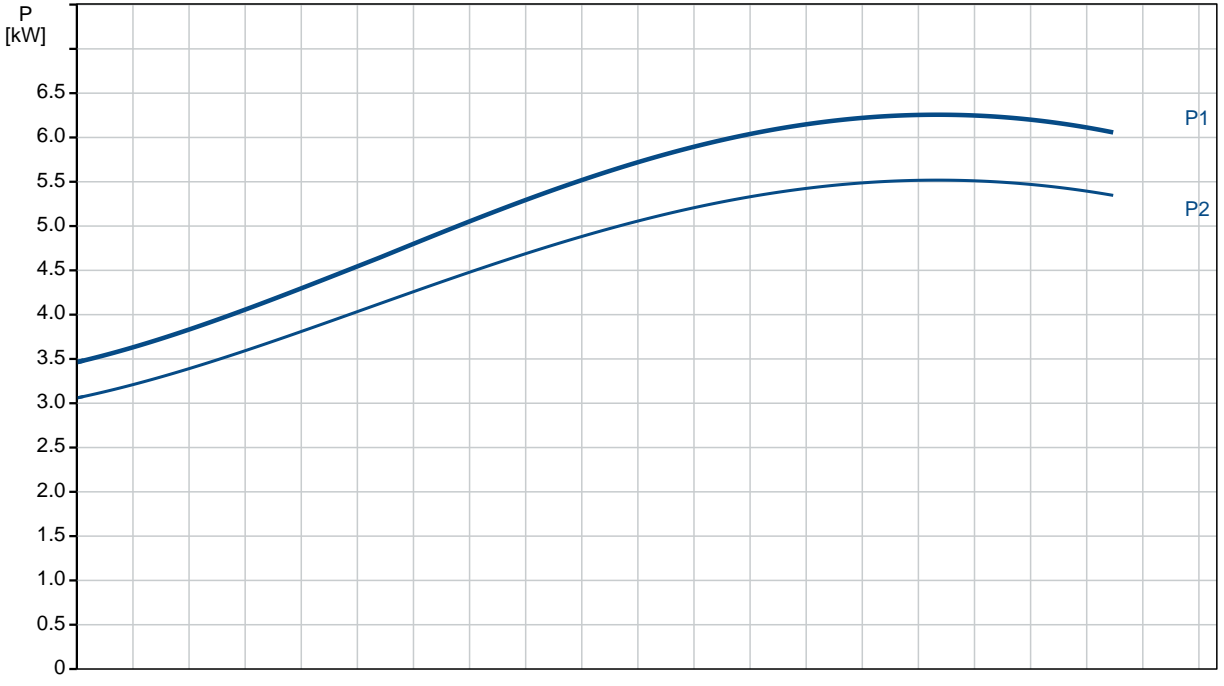
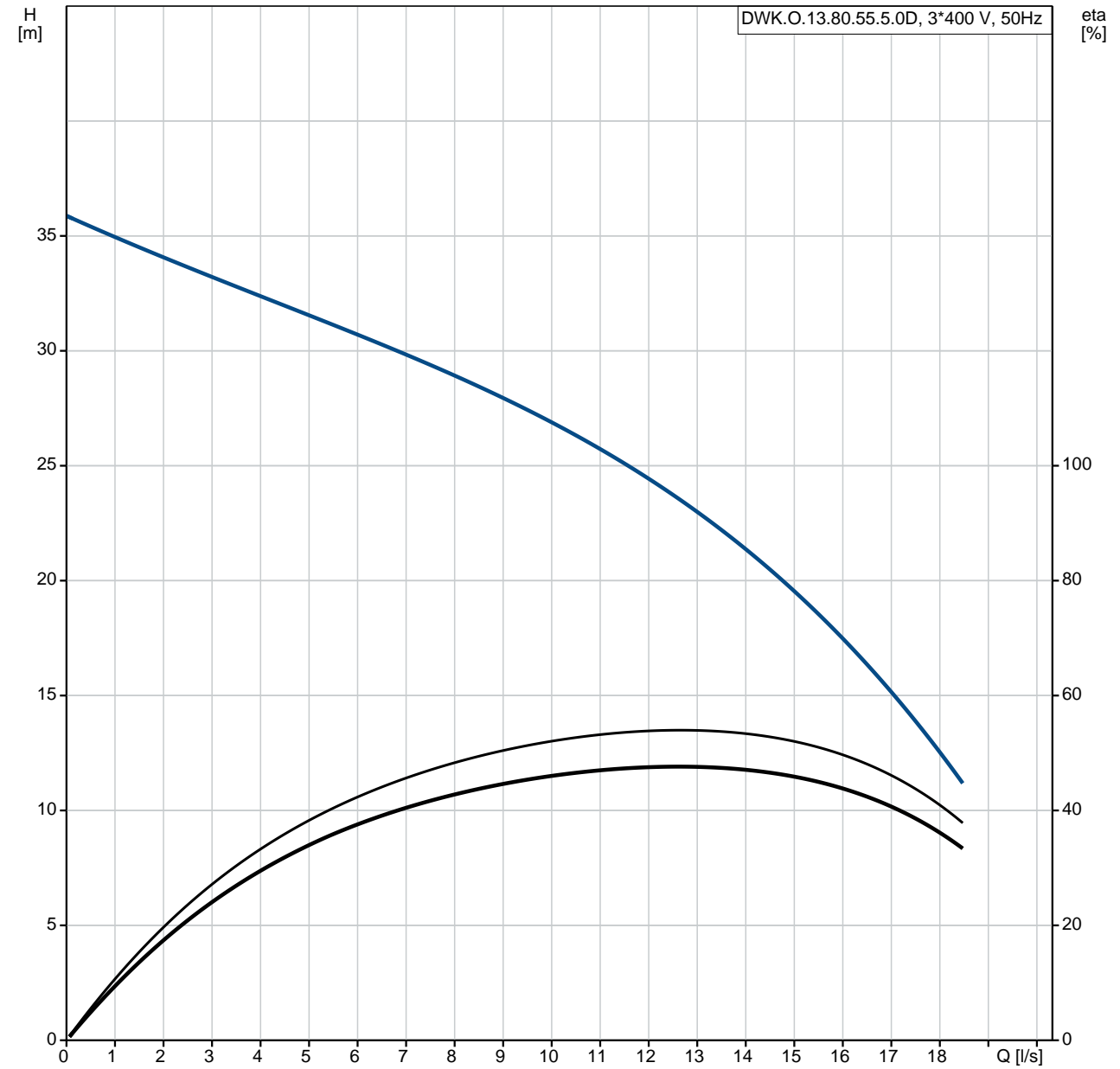

Description	Value
<b>General information:</b>	
Product name:	DWK.O.13.80.55.5.0D
Product No:	On request
EAN number:	On request
<b>Technical:</b>	
Max flow:	18.3 l/s
Head min:	9.6 m
Head max:	33.9 m
Actual impeller diameter:	174 mm
Type of impeller:	O
Maximum particle size:	13 mm
Primary shaft seal:	SIC-SIC
Secondary shaft seal:	CERAMIC-CARBON
Max. hydraulic efficiency:	51 %
Curve tolerance:	NONE
<b>Materials:</b>	
Pump housing:	Cast iron EN1561 EN-GJL-200
Impeller:	Ductile cast iron EN1563 EN-GJS-450-10
Motor:	Cast iron EN1561 EN-GJL-200
<b>Installation:</b>	
Maximum ambient temperature:	40 °C
Pump outlet:	DN 80
Maximum installation depth:	25 m
<b>Liquid:</b>	
Liquid temperature range:	0 .. 40 °C
Density:	998.2 kg/m <sup>3</sup>
Min. pH-value:	4
<b>Electrical data:</b>	
Rated power - P2:	5.5 kW
Mains frequency:	50 Hz
Rated voltage:	3 x 380-415 V
Voltage tolerance:	+5/-5 %
Max starts per. hour:	30
Rated current:	10.5 A
Rated current at 3/4 load:	8 A
Rated current at 1/2 load:	5.9 A
Cos phi - power factor:	0.91
Cos phi - p.f. at 3/4 load:	0.88
Cos phi - p.f. at 1/2 load:	0.82
Rated speed:	2850 rpm
Motor efficiency at full load:	88.2 %
Motor efficiency at 3/4 load:	88.8 %
Motor efficiency at 1/2 load:	88.2 %
Number of poles:	2
Start. method:	direct-on-line
Enclosure class (IEC 34-5):	IP68
Insulation class (IEC 85):	F
Explosion proof:	no
Length of cable:	10 m
Cable type:	TP90/TP90
Cable size:	4X2.5MM <sup>2</sup> +4X1MM <sup>2</sup>
<b>Controls:</b>	
Seal sensor:	N
Sensor type:	Y
<b>Others:</b>	
Net weight:	110 kg

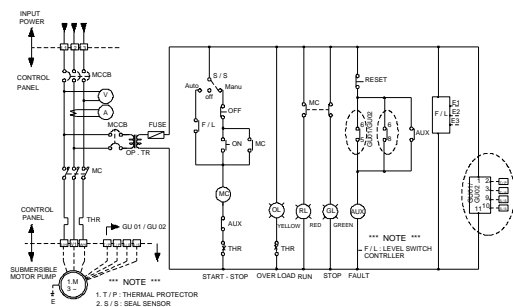
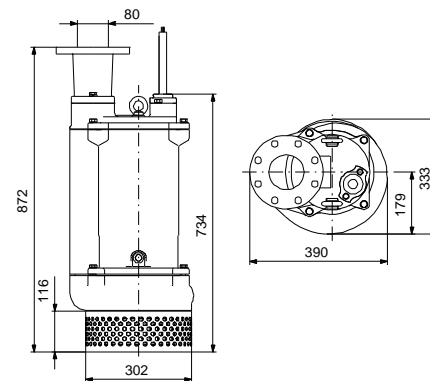
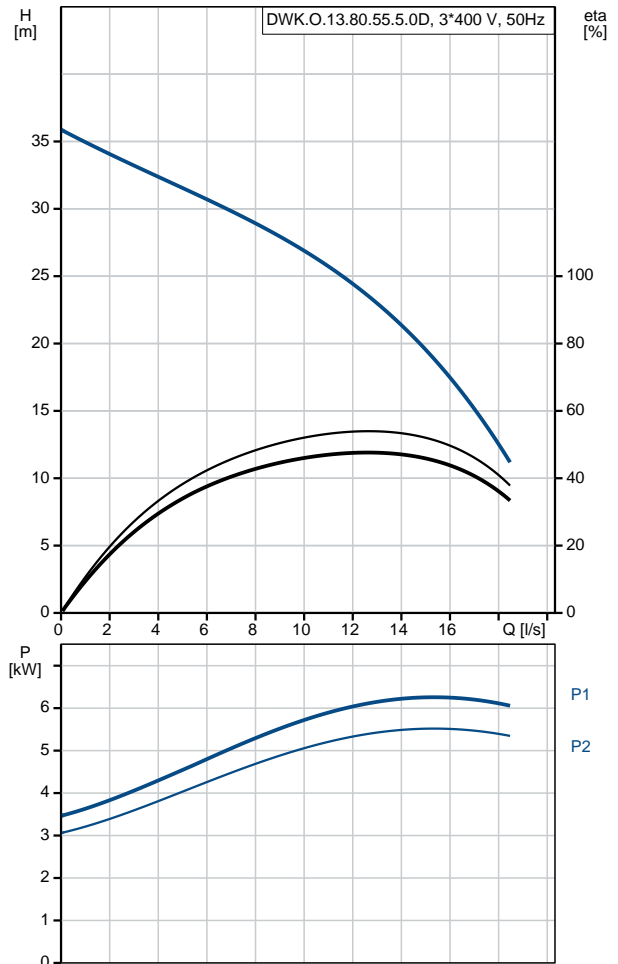

**On request DWK.O.13.80.55.5.0D 50 Hz**

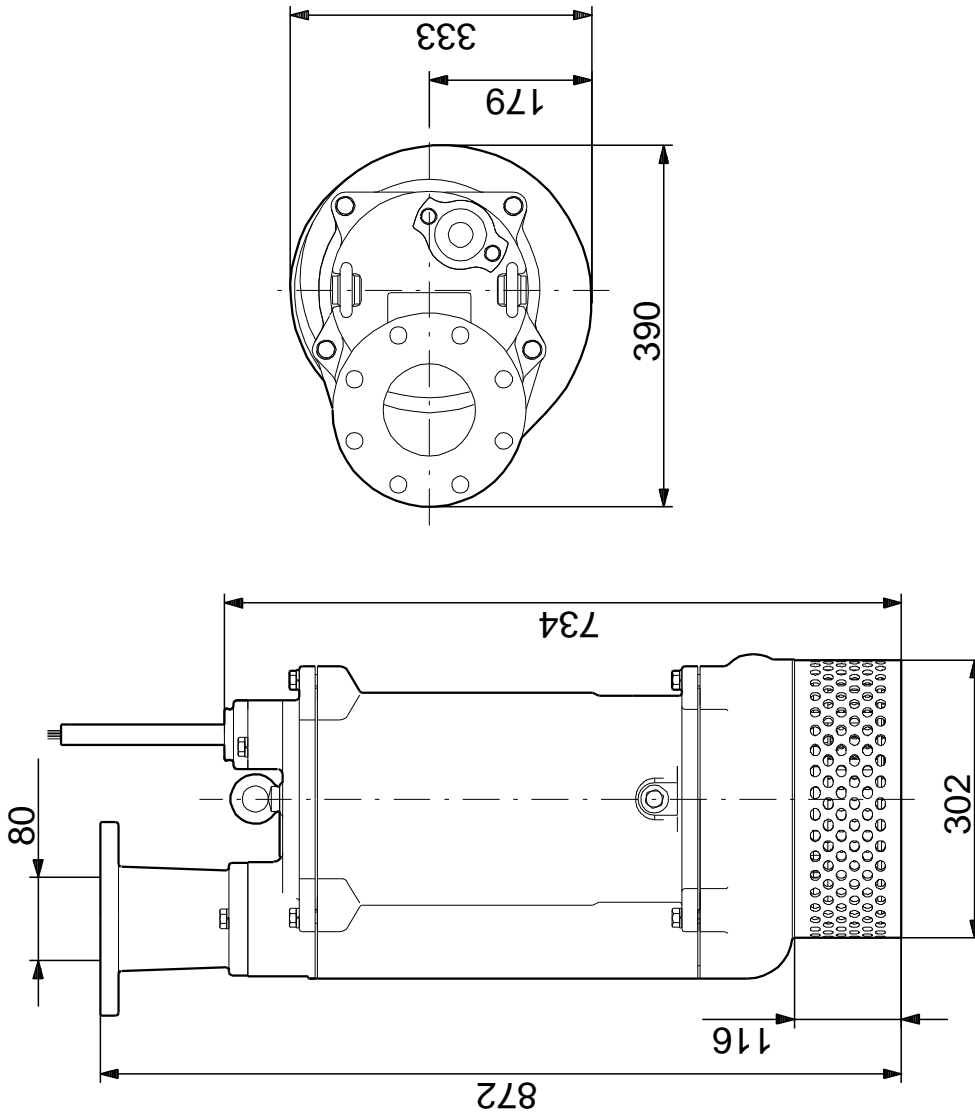

Note! All units are in [mm] unless others are stated.  
Disclaimer: This simplified dimensional drawing does not show all details.

Exploded view

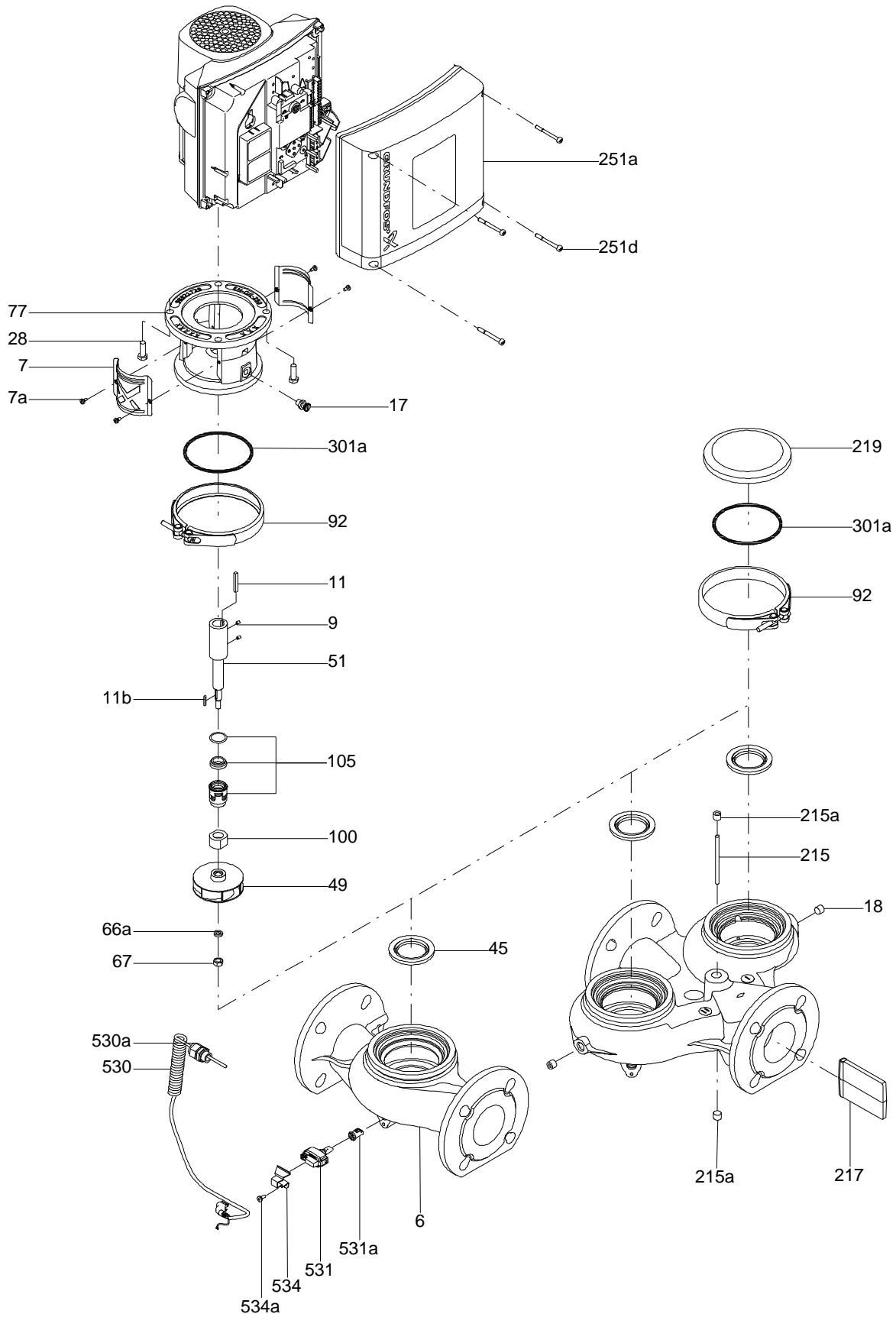

Sectional drawing (TM058200 for TPE2,TPE3)

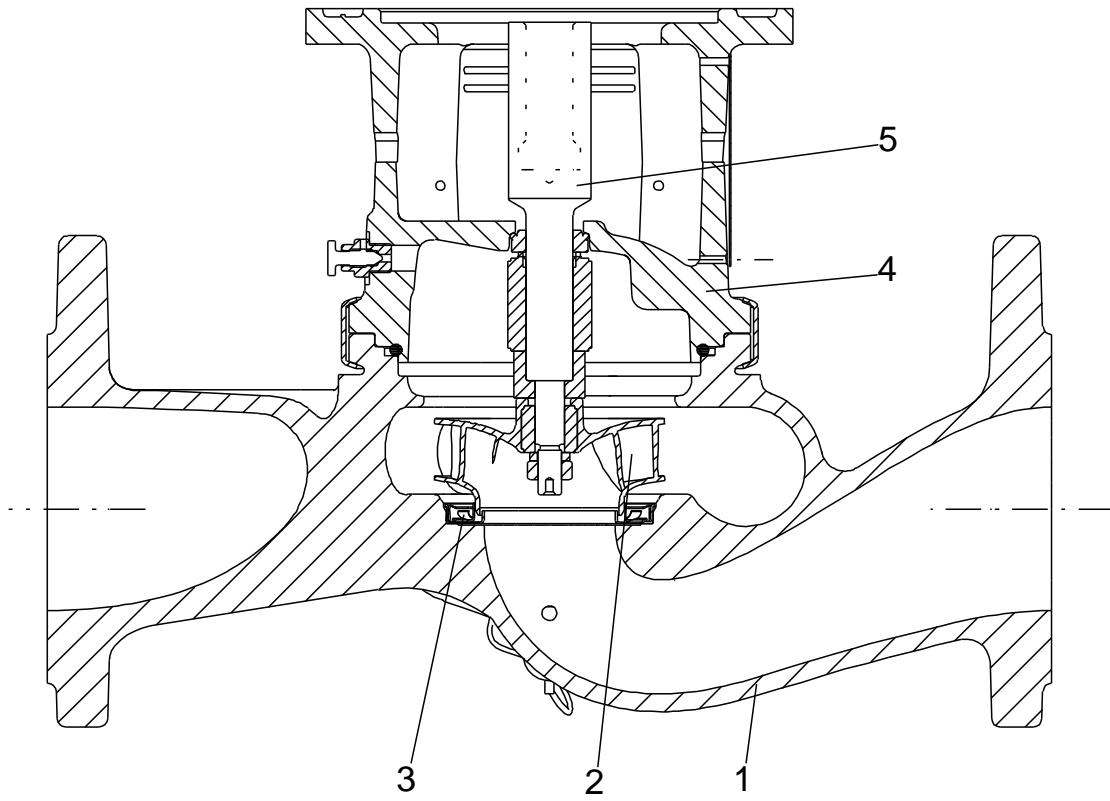

TM058200



Exploded view ( TM057026 for MGE model H/I )

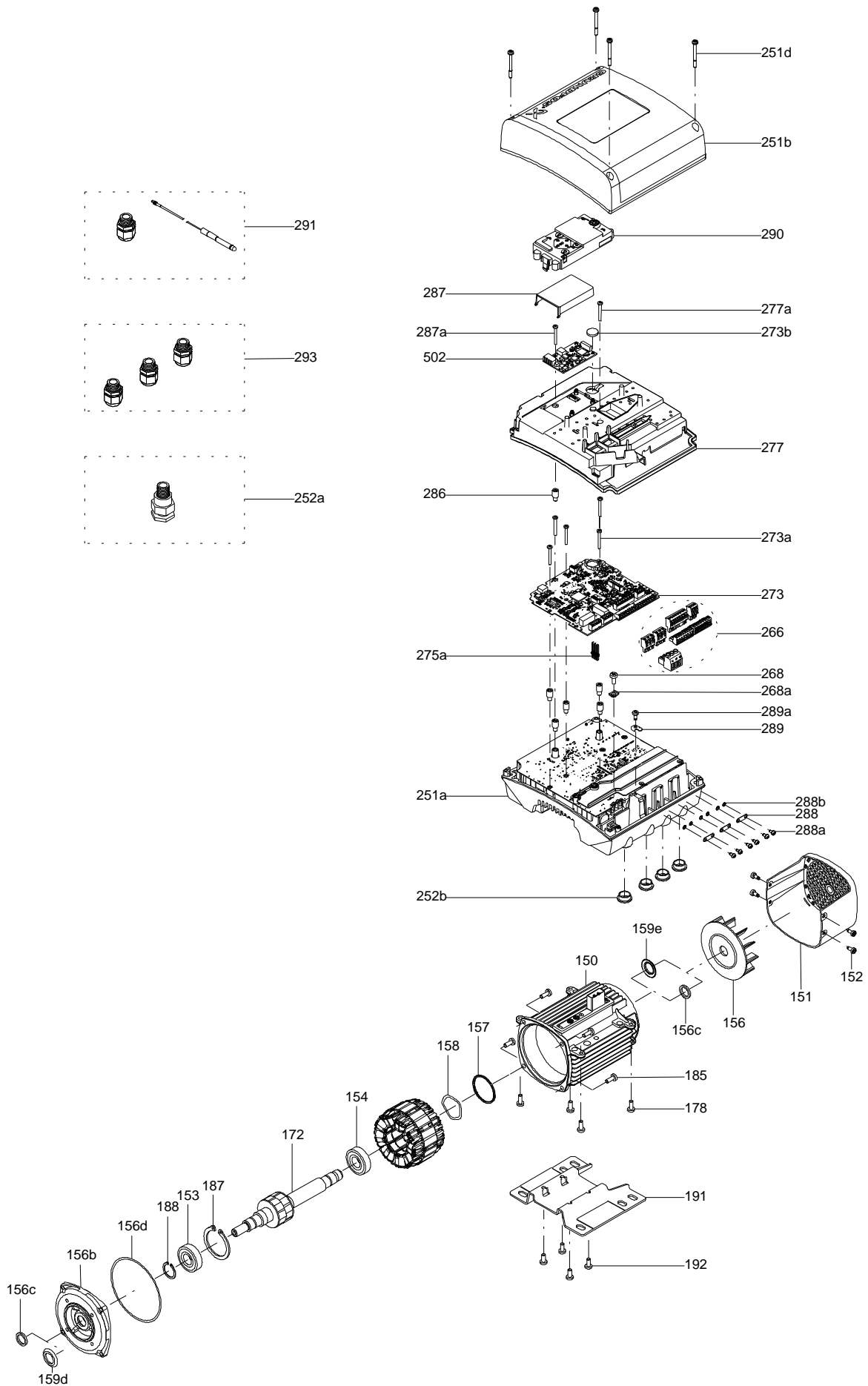

**Parts list DWK.O.13.80.55.5.0D, Product No. On request  
Valid from 1.5.2009 (0918)**

Pos	Description	Annotation	Données de classification	Référence	Quantité	Unité
-	Flange				1	pcs
12	Flange				1	
35	Hex head bolt				4	
35b	Spring lock washer				4	
-	O-ring				1	pcs
35a	O-ring				1	
37b	O-ring				1	
37e	Rubber				1	
39	O-ring				1	
39e	Rubber				1	
109	O-ring				1	
-	Cable				1	pcs
	Hex head screw				1	
	Hex head screw				1	
	Nut				1	
	Nut				1	
	Clamp				1	
	Rubber bush				1	
	Cable clamp				1	
168	Cable gland				1	
181	Cable				1	
181a	Hex head bolt				2	
181b	Spring lock washer				2	
198	Rubber bush				2	
198a	Washer				2	
-	Motor assembly				1	pcs
	Bolt				1	
	Sensor				1	
	Hex head bolt				2	
48	Stator				1	
55	Motor housing				1	
59	Bearing cover				1	
60	Bearing housing				1	
60a	Hex head screw				4	
60b	Spring lock washer				4	
102	Stop ring				1	
151	Bracket				1	
153	Angular-contact bearing				1	
153a	Ball bearing				1	
154	Ball bearing				1	
154a	Insulation plate				1	
172	Shaft w/rotor				1	
182	Hex head screw				6	
182a	Spring lock washer				6	
183	Hex head screw				4	
183a	Spring lock washer				4	
183b	Hex head bolt				2	
183c	Spring lock washer				2	
184	Hex head screw				4	
184a	Spring lock washer				4	
190d	Eyebolt				2	
193	Plug				2	
-	Hydraulic assembly				1	pcs
9a	Key				1	
46	Sealing part				2	
49	Impeller				1	
50	Pump housing				1	
66	Washer				1	
84a	Strainer				1	

Pos	Description	Annotation	Données de classification	Référence	Quantité	Unité
84b	Hex head screw				3	
84c	Spring lock washer				3	
105	Mechanical seal cpl.				1	
105b	Pan head screw				3	
188	Cap nut				1	
188a	Hex head screw				3	
188b	Spring lock washer				3	
189	Suction cover				1	

*Disclaimer: The information about the Grundfos pump in this document may be outdated.*

*Data may be subject to alterations without further notice.*

*Please contact us to verify the data above is still accurate/up-to-date.*

All information is copyright Grundfos.



[info@lenntech.com](mailto:info@lenntech.com)

<https://www.lenntech.com>

tel. +31 152 610 900

fax. +31 152 616 289